

1600 Series with P4

Industrial PC Computer System

User Manual for the
1612, 1613, & 1614
models

Revision	Description	Date
A	Manual Released	10/03
B	Added SBC-860 Watchdog Timer Appendix	4/04
C	RAID-Enabled Appendix added	10/04

Part Number 143158 (C)**Trademark Information**

Brand or product names are trademarks or registered trademarks of their respective owners. Intel and Pentium are registered trademarks and Celeron is a trademark of Intel Corporation. Windows, Windows NT, and Windows XP are registered trademarks of Microsoft Corporation in the U.S. and in other countries.

Copyright Information

This document is copyrighted by Xycom Incorporated (Xycom) and shall not be reproduced or copied without expressed written authorization from Xycom.

The information contained within this document is subject to change without notice. Xycom does not guarantee the accuracy of the information and makes no commitment toward keeping it up to date.

United States FCC Part 15, Subpart B, Class A EMI Compliance Statement:

NOTE: This equipment has been tested and found to comply with the limits for a Class A digital device, pursuant to part 15 of the FCC Rules. These limits are designed to provide reasonable protection against harmful interference when the equipment is operated in a commercial environment. This equipment generates, uses, and can radiate radio frequency energy and, if not installed and used in accordance with the instruction manual, may cause harmful interference to radio communications. Operation of this equipment in a residential area is likely to cause harmful interference in which case the user will be required to correct the interference at his or her own expense.

For European Users – WARNING:

This is a Class A product. In a domestic environment, this product may cause radio interference in which case the user may be required to take adequate measures.

INSTALLATION: Electromagnetic Compatibility – WARNING

The connection of non-shielded equipment interface cables to this equipment will invalidate FCC EMI and European Union EMC compliance and may result in electromagnetic interference and/or susceptibility levels which are in violation of regulations which apply to the legal operation of this device. It is the responsibility of the system integrator and/or user to apply the following directions, which relate to installation and configuration:

All interface cables must include shielded cables. Braid/foil type shields are recommended. Communication cable connectors must be metal, ideally zinc die-cast backshell types, and provide 360-degree protection about the interface wires. The cable shield braid must be terminated directly to the metal connector shell; ground drain wires alone are not adequate.

Protective measures for power and interface cables as described within this manual must be applied. Do not leave cables connected to unused interfaces or disconnected at one end. Changes or modifications to this device not expressly approved by the manufacturer could void the user's authority to operate the equipment.

EMC compliance is, in part, a function of PCB design. Third party add-on AT/XT peripheral PCB assemblies installed within this apparatus may void EMC compliance. FCC/CE compliant PCB assemblies should always be used where possible. XYCOM can accept no responsibility for the EMC performance of this apparatus after system integrator or user installation of PCB assemblies not manufactured and/or expressly tested and approved for compliance by XYCOM. It is the responsibility of the system user to ensure that installation and operation of such devices does not void EMC compliance.

BATTERY REPLACEMENT CAUTION:

There is a danger of explosion if the battery is incorrectly replaced. Replace only with the same or equivalent type recommended by the manufacturer. Dispose of used batteries according to the manufacturer's instructions.

CPU REMOVAL AND REPLACEMENT CAUTION:

Use caution when removing the CPU from its board. After removing the DRAM, carefully slide the CPU from its position without bumping or bending components behind or around the CPU.

Table of Contents

1600 SERIES WITH P4	1
CHAPTER 1 – INTRODUCTION	1
PRODUCT OVERVIEW	1
STANDARD FEATURES	1
<i>Front View with Door Closed</i>	2
<i>Front View with Door Open</i>	3
<i>Back View</i>	5
<i>Internal View</i>	6
UNPACKING THE SYSTEM	7
QUICK START-UP	8
CHAPTER 2 – INSTALLATION	9
INSTALLATION OVERVIEW	9
MOUNTING DIMENSIONS	10
<i>1600 Front and Rear Dimensions</i>	10
<i>1612 Dimensions</i>	11
<i>1613 Dimensions</i>	12
<i>1614 Dimensions</i>	13
MOUNTING INSTRUCTIONS	14
<i>Rack Mounting</i>	14
<i>Rack Mounting with Slide Rails</i>	15
POWER MANAGEMENT	16
<i>System Power</i>	16
<i>Excessive Heat</i>	16
<i>Electrical Noise</i>	17
<i>Line Voltage Variation</i>	17
<i>Safety Agency Approval</i>	17
INSTALLING OPTIONS	18
<i>Additional DDR SDRAM Dual In-Line Memory Modules (DIMMs)</i>	18
<i>Adding 5.25" and 3.5" Devices</i>	18
<i>ISA/PCI Expansion</i>	19
<i>Custom Logo</i>	20
CHAPTER 3 – SBC-860 P4 BOARD & BIOS SETUP	21
SBC-860 P4 MOTHERBOARD	21
<i>Features</i>	21
<i>Mechanical Drawing</i>	22
JUMPER SETTINGS	23
<i>Front Panel (JP1)</i>	23
<i>COM2 RS-232/422/485 Selection – 1 (JP2)</i>	23
<i>COM2 RI/+5V/+12V Selection (JP3)</i>	24
<i>COM2 RS-232/422/485 Selection – 2 (JP4)</i>	24
<i>Clear CMOS (JP6)</i>	24
<i>Watch Dog Timer (JP7)</i>	24
CONNECTOR PINOUTS	25
<i>Floppy Drive Connector (CN³)</i>	25
<i>Parallel Port Connector – LPT1 (CN⁴)</i>	26
<i>ATX PWM⁴P Power Connector (CN⁵)</i>	26
<i>COM1 Serial Port Connector (CN⁸)</i>	26
<i>Primary IDE Hard Drive Connector (CN⁶)</i>	27
<i>COM2 Serial Port Connector (CN⁷)</i>	27
<i>Secondary IDE Hard Drive Connector (CN⁹)</i>	28
<i>USB 2.0 Port 1 Connector (CN¹³)</i>	29
<i>VGA Connector (CN¹⁴)</i>	29
<i>LAN RJ45 Connector (CN¹⁵ and CN¹⁷)</i>	29
<i>Audio Input/Output Connector (CN¹⁸)</i>	30
<i>PS/2 Combined Keyboard and Mouse Connector (CN¹⁹)</i>	30

Internal Keyboard Connector (CN21)	30
Internal Mouse Connector (CN22)	31
AWARD BIOS CMOS SETUP	31
STANDARD CMOS SETUP	33
ADVANCED BIOS FEATURES SETUP	35
ADVANCED CHIPSET FEATURES SETUP	38
INTEGRATED PERIPHERALS	40
POWER MANAGEMENT SETUP	44
PNP/PCI CONFIGURATION.....	47
LOAD OPTIMIZED DEFAULTS.....	49
SECURITY SETUP	49
PC HEALTH SETUP.....	49
CLK/VOLTAGE SETUP.....	50
EXIT SETUP.....	50
CHAPTER 4 – MAINTENANCE	51
GENERAL PREVENTIVE MAINTENANCE.....	51
Fan Filter Replacement.....	52
Fuse Replacement.....	52
RECOMMENDED HARD DRIVE PREVENTIVE MAINTENANCE.....	52
PRODUCT REPAIR PROGRAM.....	52
CHAPTER 5 – TROUBLESHOOTING.....	54
TROUBLESHOOTING TABLES.....	54
General Operational Problems	55
BIOS Error Messages	56
DIAGNOSTIC TESTING	57
Preparing for the Tests	57
Set BIOS to Defaults.....	57
Prepare the System	58
Running the Tests.....	59
REINSTALLING OPERATING SYSTEMS	60
MS-DOS® Reinstallation	60
Windows® 98 Reinstallation.....	60
Windows® 2000 Reinstallation.....	61
Windows NT® Reinstallation	61
Windows XP® Reinstallation	62
INSTALLING DRIVERS	62
Ethernet Drivers	62
Video Drivers	63
CD-ROM Drivers	63
Miscellaneous Drivers.....	63
APPENDIX A – TECHNICAL SPECIFICATIONS.....	64
HARDWARE SPECIFICATIONS.....	64
ENVIRONMENTAL SPECIFICATIONS	65
APPENDIX B – PROGRAMMING THE SBC-860 WATCHDOG TIMER.....	66
APPENDIX C – THE RAID-ENABLED INDUSTRIAL PC	69

Chapter 1 – Introduction

Product Overview

The Xycom Automation 1600 Industrial Rack Mount PCs put the power and versatility of a PC-compatible computer in an industry standard package. It is ideal for the factory floor and other industrial applications. The 1600 industrial rack mount PC meets the requirements of a wide variety of applications where both a powerful PC and a durable industrial enclosure are required.

The system integrates the computer card cage, mass storage options, and power supply options in a truly industrial standard 19" EIA form factor with rack mount 4U height. The open architecture design accepts ISA and PCI cards and allows easy access to the boards, switches, power supply, and drives.

Standard Features

The 1600 offers the following standard features:

- Rack mount 4U height and 3 sizes for various length expansion capabilities
- Intel Socket 478 2.0 GHz Pentium 4, 512 KB cache, 400 MHz system bus
- 14-slot passive backplane with 10 available expansion slots
- 4X AGP video controller with 8 MB base and 64 MB system RAM usage
- Up to 1GB DDR SDRAM (512 MB on Windows 95 and Windows 98)
- External connection ports
 - Two serial ports, with one configured as RS-232 and one configurable as either RS-232, RS-422, or RS-485)
 - One parallel port
 - Two PS/2 keyboard and mouse ports, one behind the front door and one on the back of unit (you will need to use a Y cable adapter there)
 - Audio In, Audio Out, and Audio Mic (does not work with MS-DOS)
 - Two USB 2.0 ports
- Dual 10/100 Base-T Ethernet ports
- 300 Watt AC power supply and optional dual redundant power supply
- Lockable front door panel
- Three 5.25" front accessible drive bays
- Either a 20 GB or a 40 GB internal hard drive
- Power-on switch and reset switch with HDD LED indicator
- 82 CFM cooling fan

- Hold-down clamp, which protects add-on cards from vibration
- Preloaded with MS-DOS®, Windows® 98, NT, 2000, or XP

The figures and tables on the next several pages illustrate the internal and external components on the 1600 unit to help you locate features relevant to installation.

Front View with Door Closed

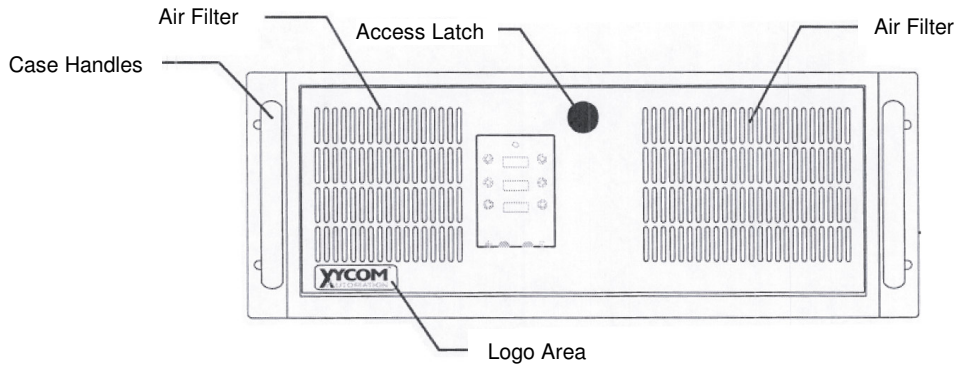
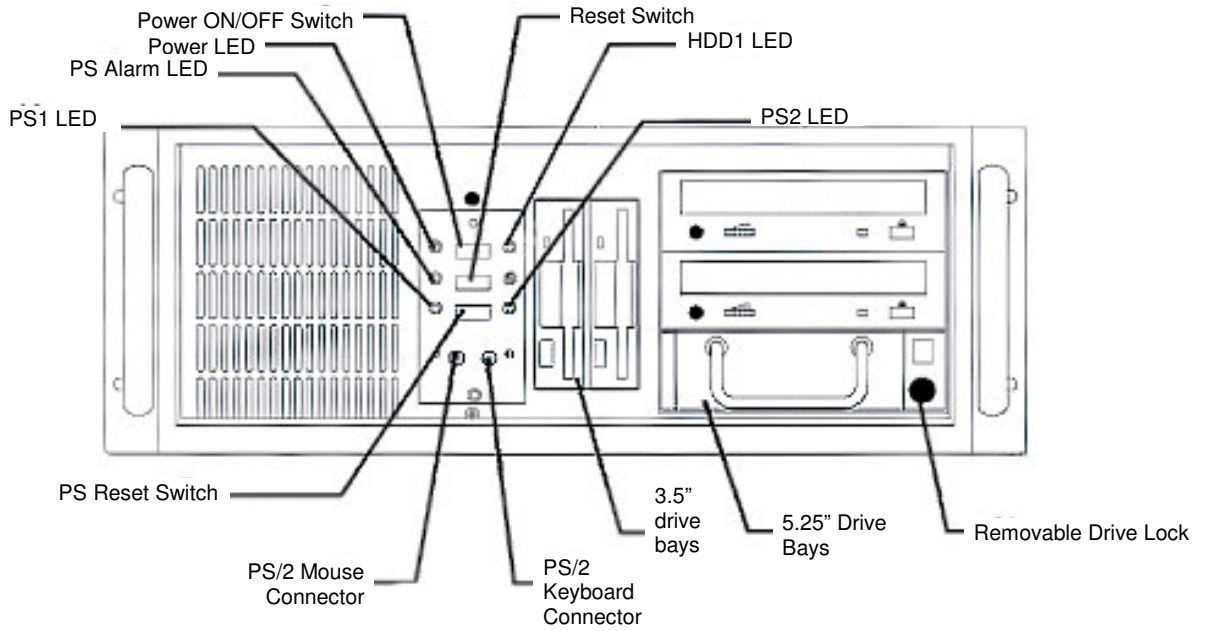

Figure 1-1. Front View with Door Closed

Table 1-1. Features on the Front Panel Door

Feature	Description
Logo Area	The front panel incorporates a logo panel that can be customized. Label dimensions and recommended requirements for a customized label are depicted in Figure 2-16.
Case Handles	These handles can be used to carry the 1600 and to maneuver it into position when mounting.
Air Filters	Two air filters are mounted in each side of the front door. These filters separate particulate contaminants from the cooling air drawn into the 1600. See page 51 for instructions on cleaning air filters.
Access Latch	The front panel door latches and locks. The knob does not have to be locked in order for the door to stay closed.

Front View with Door Open



Note: Model shown with redundant power supply option.

Figure 1-2. Front View with Door Open

Table 1-2. Features on the Front of the Unit

Feature	Description
Power ON/OFF Switch	This switch should be positioned to OFF (O) until the system is properly configured and connected to an appropriate power source.
Reset Switch	This switch restarts the computer.
PS Reset Switch	The power supply (PS) reset switch resets the power supply alarm when triggered by a power supply interruption. This switch is present only on units with dual redundant 300 watt AC power supply.
Diagnostic LEDs	<p>Power Lit when there is power to the 1600.</p> <p>HDD1 Lit when the hard drive is being accessed.</p> <p>The following LEDs apply only to units with dual redundant power supplies:</p> <p>PS Alarm Flashes when a power supply malfunctions.</p> <p>PS1 Lit when first power supply is functioning properly.</p> <p>PS2 Lit when second power supply is functioning properly.</p>
PS/2 Mouse Connector	<p>A mouse can interface with the system via this 6-pin PS/2-compatible connector.</p> <p>Caution: Do not connect a mouse to this front connector if a mouse is plugged into the mouse connector on the rear panel.</p>
PS/2 Keyboard Connector	<p>A keyboard can interface with the system via this 6-pin PS/2-compatible connector.</p> <p>Caution: Do not connect a keyboard to this front connector if a keyboard is plugged into the keyboard connector on the rear panel.</p>
3.5" Drive Bays	These front accessible bays can hold up to two 3.5" storage devices, including 1.44 MB floppy and internal hard drives.
5.25" Drive Bays	<p>These bays hold up to three 5.25" mass storage devices, including CD-ROM, CD-Writable, Zip, and removable hard drives.</p> <p>Note: The unit holds a maximum of four IDE devices.</p>
Removable Drive Lock	If a removable drive is installed in the system, it must be locked in order to operate. The display above the lock shows an O when locked, and a U when unlocked. The display also flashes when the removable hard drive is active.

Back View

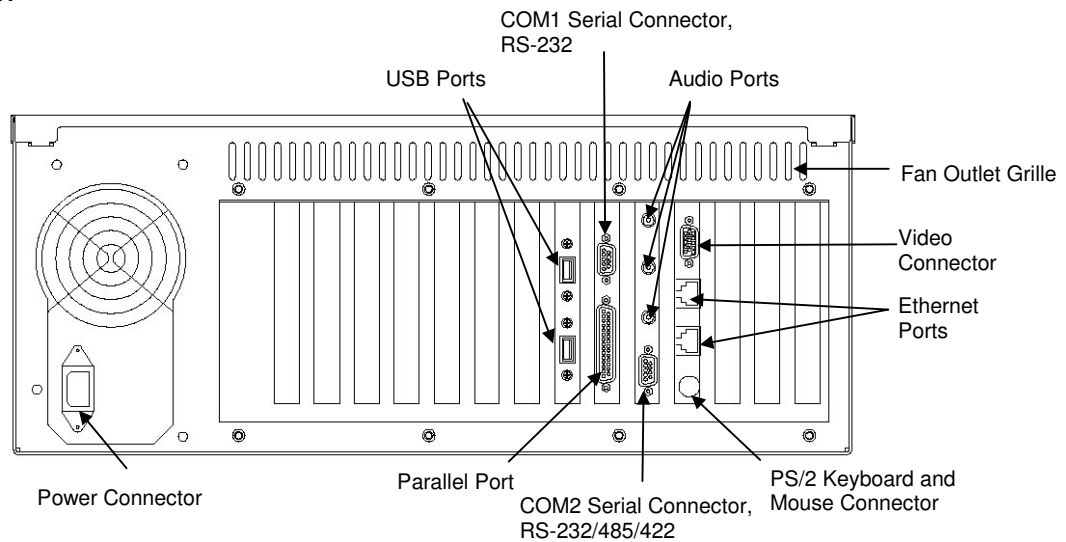

Figure 1-3. Back View of Unit

Table 1-3. Features on the Back of the Unit

Feature	Description
Power Connector	For AC power units, the standard power cord must be securely positioned before turning power ON. The 1600's autoranging AC power supply requires no switch adjustment.
Parallel Port	A printer usually interfaces with the system through this 25-pin connector. See page 25 for parallel port pinouts.
PS/2 Keyboard and Mouse Connector	A keyboard and a mouse can be connected to this PS/2 compatible port through the Y-adapter cable included with the unit. If connecting only a keyboard, connect directly to the PS/2 compatible connector on the back of the unit. If connecting only mouse, the mouse must be connected using the Y-adapter cable port with the mouse icon on it. See page 30 for keyboard/mouse connector pinouts.
COM1 Serial Connector, RS-232	COM1 is RS-232 only. See page 23 for jumper settings.
COM2 Serial Connector, RS-232/485/422	COM2 can be configured as either RS-232, RS-422, or RS-485. See page 23 for jumper settings.
Ethernet Ports	These RJ45 connectors provide 10 BaseT and 100 BaseTX autosensing Ethernet connections.
Video Connector	This 15-pin high-density female connector is used to connect a monitor to the unit's video output. See page 29 for video connector pinouts.
Fan Outlet Grille	Unobstructed airflow is essential to proper ventilation and cooling of the unit. Do not block this outlet.

Internal View

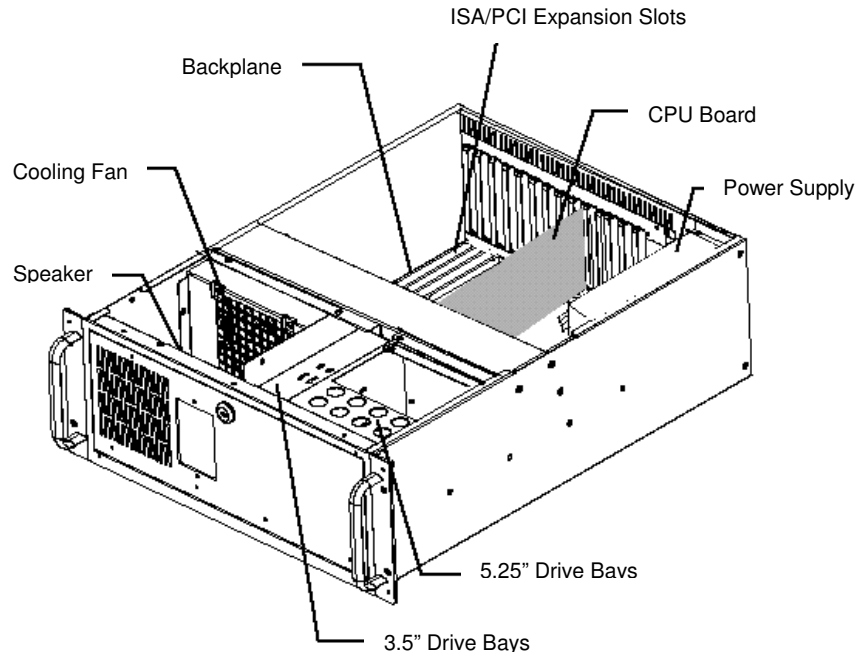

Figure 1-4. Internal View

Table 1-4. Internal Features and Descriptions

Feature	Description															
Backplane	14-slot passive backplane with 10 available expansion slots															
ISA/PCI Expansion Slots	<table border="0"> <tr> <td>1612</td> <td>1613</td> <td>1614</td> </tr> <tr> <td>Three full-length ISA</td> <td>Three full-length ISA</td> <td>Three full-length ISA</td> </tr> <tr> <td>One full-length PCI</td> <td>One full-length PCI</td> <td>Four full-length PCI</td> </tr> <tr> <td>Two ¾ length PCI</td> <td>Six ¾ length PCI</td> <td>Three ¾ length PCI</td> </tr> <tr> <td>Four ½ length PCI</td> <td></td> <td></td> </tr> </table> <p>Note: See page 19 for instructions on adding expansion cards.</p>	1612	1613	1614	Three full-length ISA	Three full-length ISA	Three full-length ISA	One full-length PCI	One full-length PCI	Four full-length PCI	Two ¾ length PCI	Six ¾ length PCI	Three ¾ length PCI	Four ½ length PCI		
1612	1613	1614														
Three full-length ISA	Three full-length ISA	Three full-length ISA														
One full-length PCI	One full-length PCI	Four full-length PCI														
Two ¾ length PCI	Six ¾ length PCI	Three ¾ length PCI														
Four ½ length PCI																
CPU Board	SBC-860 full-size CPU card: Socket 478-based Intel Pentium 4 processor with integrated Intel 82845GV chipset, DDR, USB 2.0, and Ethernet.															
Power Supply	The power supply is located on the back of the unit. The 1600 comes standard with a 300 watt AC power supply. A dual redundant 300 watt AC power supply is optional. See page 64 for power supply specifications.															
5.25" Drive Bays	See page 18 for instructions on adding and removing 5.25" devices.															
3.5" Drive Bays	See page 18 for instructions on adding and removing 3.5" devices.															
Speaker	This speaker provides buzzing alarms when signaled by software applications.															
Cooling Fan	This 82 CFM cooling fan dissipates heat in the chassis.															

Unpacking the System

When you remove the 1600 from its box, verify that you have the parts listed below. Save the box and inner wrapping in the event you need to reship the unit.

- 1600 unit
- AC power cord
- Y-adapter cable
- Key for lockable front door panel
- Documentation kit, which includes:
 - Diagnostic software disk (units shipped with MS-DOS only)
 - Documentation Support Library CD (documentation and drivers)
 - 1600 manual
 - Drivers
 - Zip drive Iomegaware software (if applicable)

Note

There may be a newer revision than the software that is pre-configured with the 1600. The software may be updated by following the installation instructions found on the Iomegaware CD.

- Xycom Automation Recovery Media and documentation for MS-DOS, Windows 98, Windows NT, Windows 2000 (whichever applies)
- Installation disk for Windows XP (if applicable)
- 28" Ultra ATA IDE cable (for systems pre-configured with only 2 IDE devices)

Quick Start-up

This section gives you the steps to get the 1600 up and running without explaining the capabilities and options of the system.

Warning

Turn off the power to the unit and disconnect the power cord before adjusting the inside or the outside of the computer.

To prepare the system for use, perform the following steps:

1. Attach a keyboard to the keyboard port.
2. Attach a monitor to the VGA connector.
3. Attach other optional equipment by following the instructions on page 9.
4. Attach the power cord from the power receptacle to a properly grounded 115/230 VAC, 50-60 Hz outlet.
5. Turn on the power to the unit.
6. The system will boot up to the C:\ prompt or to the Windows desktop.
7. Install application software that you will use onto your system via the floppy drive, CD-ROM drive, or network.

Chapter 2 – Installation

This chapter offers detailed installation instructions and outlines the options for the 1600 series. It also includes the guidelines for preparing your 1600 unit for installation and use.

Installation Overview

Here are some factors to take into account before mounting your 1600 unit inside an enclosure:

- Select an enclosure and place the unit in a position that allows easy access to the 1600 ports.
- Account for the unit's depth when choosing the depth of the enclosure.
- The unit must be mounted in an approved fire and electrical enclosure.
- See the section *Mounting Dimensions* for the dimensions and mounting instructions.
- Consider locations of accessories such as AC power outlets for installation and maintenance convenience.
- Prevent condensation by installing a thermostat-controlled heater or air conditioner.
- To allow for maximum cooling, avoid obstructing the airflow.
- Place any fans or blowers close to the heat generating devices. If using a fan, ensure that outside air is not brought inside the enclosure unless a fabric or other reliable filter is used. This filtration prevents conductive particles or other harmful contaminants from entering the enclosure.
- Do not select a location near equipment that generates excessive electromagnetic interference (EMI) or radio frequency interface (RFI) (equipment such as high power welding machines, induction heating equipment and large motor starters).
- Place incoming power line devices (such as isolation or constant voltage transformers, local power disconnects, and surge suppressers) away from the 1600. The proper location of incoming line devices keeps power wire runs as short as possible and minimizes electrical noise transmitted to the 1600.
- The power cord outlet must be installed near the equipment and should be easily accessible.
- Avoid overloading the supply circuit.
- Incorporate a readily accessible disconnect device in the fixed wiring for permanently connected systems.
- Make sure the location does not exceed the 1600's shock, vibration, and temperature specifications.

Mounting Dimensions

Figures Figure 2-1, Figure 2-2, and Figure 2-3 show the unit box dimensions for the 1600 series. Figures Figure 2-4 through Figure 2-8 show unique unit dimensions for the 1612, 1613, and 1614. Optional slide rails and wall or shelf mounting kits are available. All of the following dimensions are in inches (mm).

1600 Front and Rear Dimensions

NOTE: All dimensions are in inches (mm).

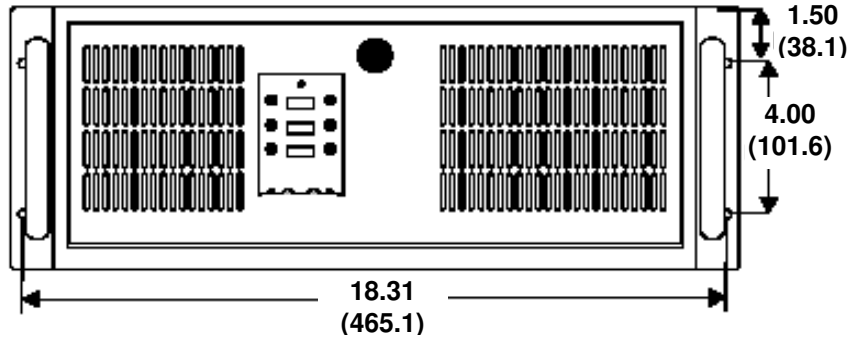

Figure 2-1. Front Dimensions with Door Closed

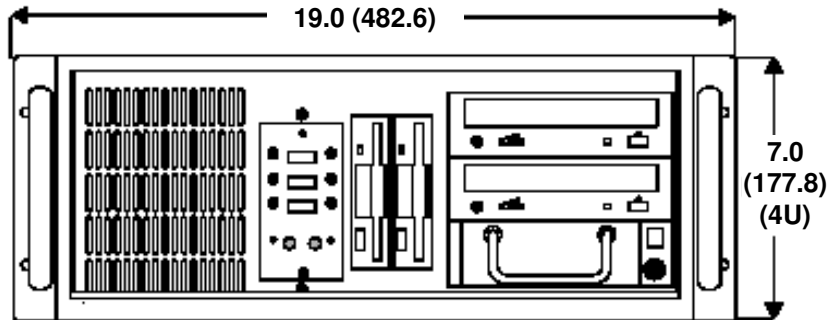

Figure 2-2. Front View Dimensions

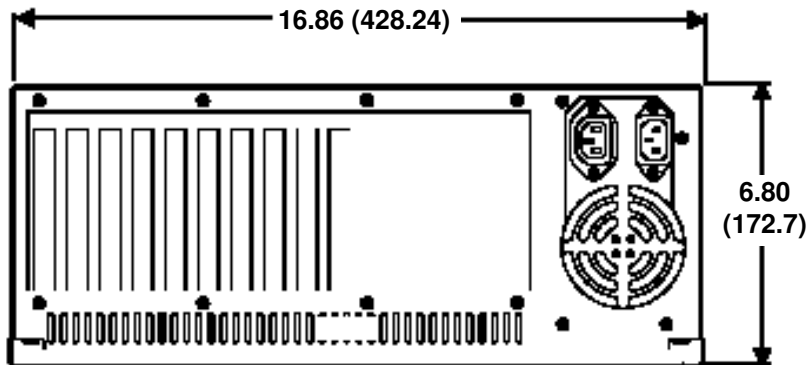

Figure 2-3. Rear View Dimensions

1612 Dimensions

NOTE: All dimensions are in inches (mm).

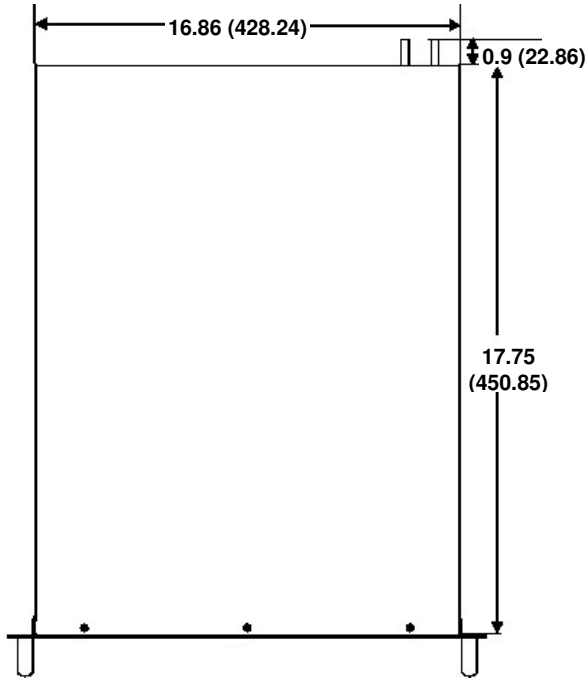

Figure 2-4. Top View Dimensions

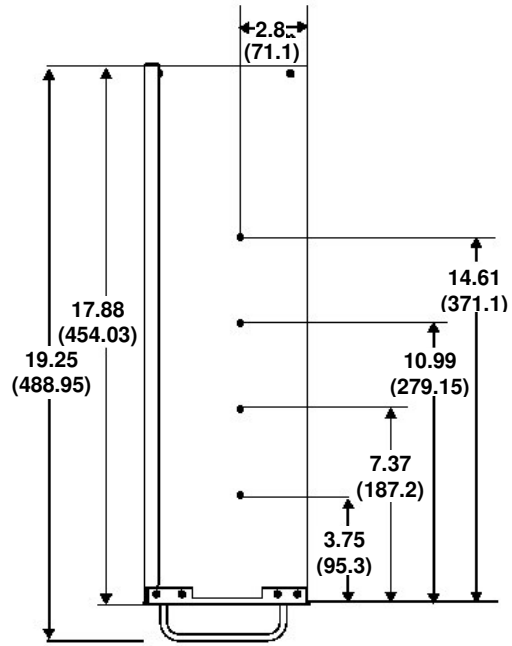

Figure 2-5. Side View Dimensions

1613 Dimensions

NOTE: All dimensions are in inches (mm).

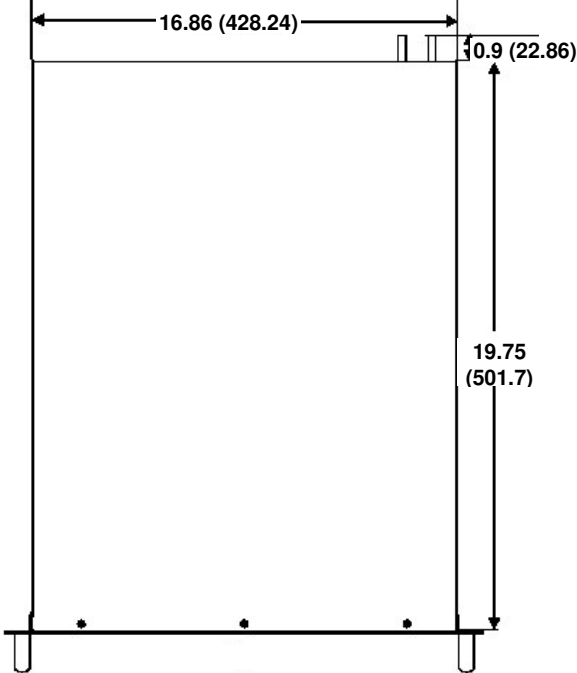

Figure 2-6. Top View Dimensions

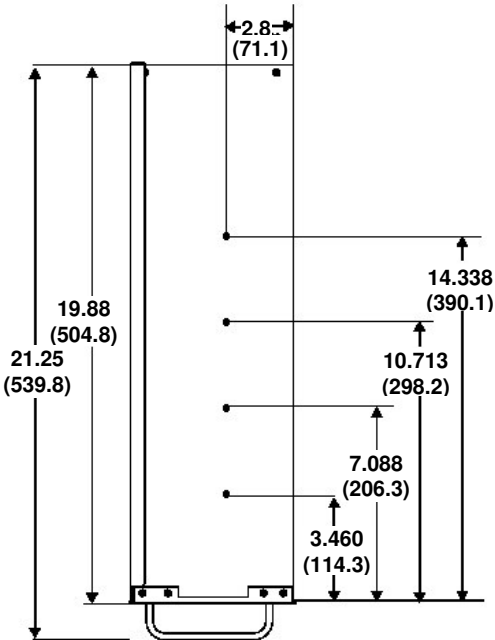

Figure 2-7. Side View Dimensions

1614 Dimensions

NOTE: All dimensions are in inches (mm).

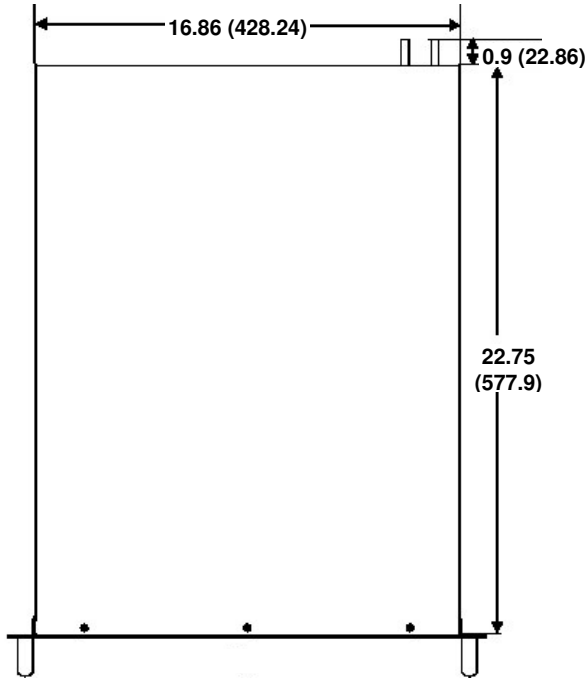

Figure 2-8. Top View Dimensions

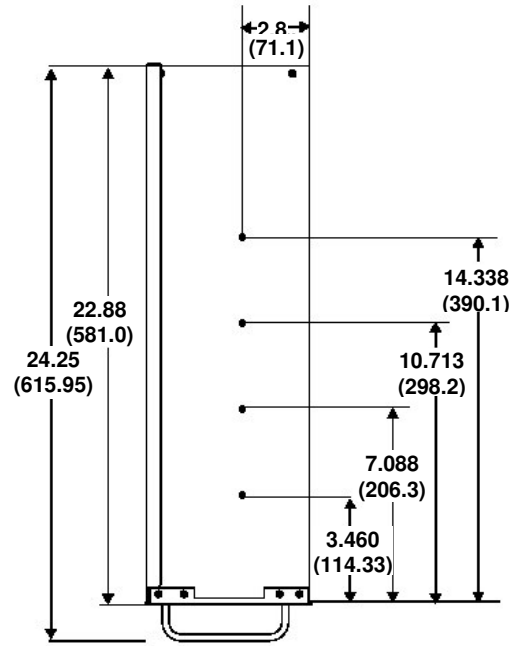

Figure 2-9. Side View Dimensions

Mounting Instructions

Rack Mounting

1. Select and prepare an appropriate mounting location according to the section *Installation Overview*.
2. Install the unit in the rack (with drive access facing outward) using the standard rack-mounting hardware.
3. Attach one end of the power cord to the power receptacle and the other end to a properly grounded 115/230 VAC, 50-60 Hz outlet.
4. Turn on the power. The system will boot up to the installed operating system.
5. Install application software via a floppy drive or CD-ROM.

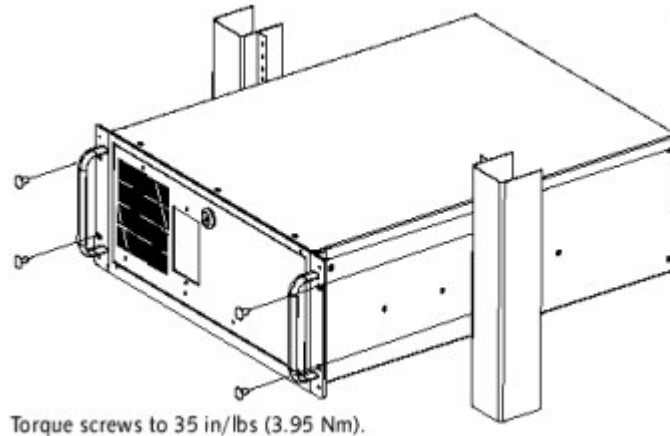

Figure 2-10. Installing Rack Mounting Hardware

Rack Mounting with Slide Rails

1. Place the unit on a solid work surface and disconnect all cables and cords from the unit.
2. Attach the provided Xycom slide rails* to the unit (see Figure 2-11).
3. Install the unit securely in the rack with standard rack-mounting hardware so that the drive access door faces outward.
4. Torque the rail-mounting screws to 35 in/lbs.
5. Reconnect all cables and cords.

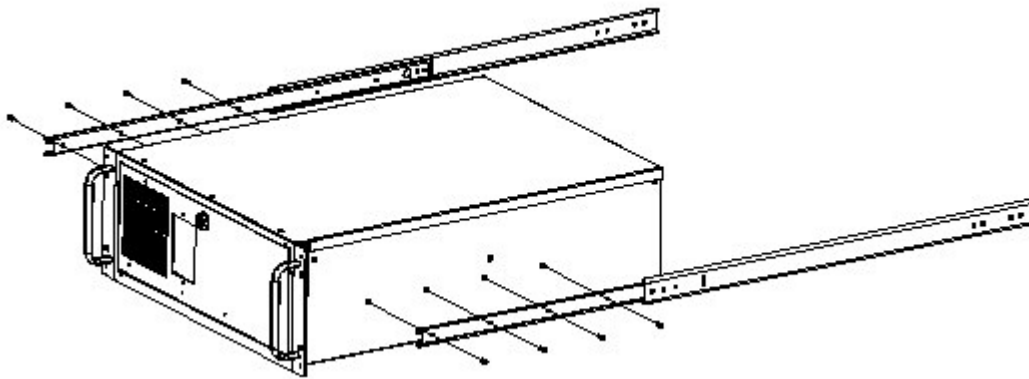

Figure 2-11. Installing Optional Slide Rails

** The slide rails are ordered separately. Use Xycom Automation order number 1600-RMS.*

Power Management

The following paragraphs explain the system power, the power supply, and the effects of excessive heat, electrical noise, and line voltage variation of the 1600 unit.

System Power

It is always a good idea to use isolation transformers on the incoming AC power line to the 1600. An isolation transformer is especially desirable in cases where heavy equipment is likely to introduce noise onto the AC line. The isolation transformer can also serve as a step-down transformer to reduce the incoming line voltage to a desired level. The transformer should have a sufficient power rating (units of volt-amperes) to supply the load adequately.

Proper grounding is essential to all safe electrical installations. Refer to the relevant Federal, State, Provincial, and local electric codes that provide data such as the size and types of conductors, color codes and connections necessary for safe grounding of electrical components. The code specifies that a grounding path must be permanent (no solder), continuous, and able to safely conduct the ground-fault current in the system with minimal impedance (minimum wire required is 18 AWG, 1 mm).

Observe the following practices:

- Separate ground wires (P.E. or Protective Earth) from power wires at the point of entry to the enclosure. To minimize the ground wire length within the enclosure, locate the ground reference point near the point of entry for the plant power supply.
- All electrical racks or chassis and machine elements should be Earth Grounded in installations where high levels of electrical noise are expected. Ground the chassis with a ground rod or attach to a nearby Earth structure such as a steel support beam. Each different apparatus should be connected to a single Earth Ground point in a “star” configuration with low impedance cable. Scrape away paint and other nonconductive material from the area where a chassis makes contact with the enclosure. In addition to the ground connection made through the mounting bolt or stud, use a one-inch metal braid or size #8 AWG wire to connect between each chassis and the enclosure at the mounting bolt or stud.

Excessive Heat

The 1600 withstands operating temperatures from 0° to 50° C (32° to 122° F). To keep the temperature in range, the cooling air at the base of the system must not exceed 50°C. Allocate proper spacing between internal components installed in the enclosure.

When the air temperature is higher than 50°C in the enclosure use a fan or air conditioner.

Electrical Noise

Electrical noise is seldom responsible for damaging components, unless extremely high energy or high voltage levels are present. However, noise can cause temporary malfunctions that can result in hazardous machine operation in certain applications. Noise may be present only at certain times, may appear at widely spread intervals, or in some cases may exist continuously.

Noise commonly enters through input, output, and power supply lines and may also be coupled through the capacitance between these lines and noise signal carrier lines. This usually results from the presence of high voltage or long, close-spaced conductors. When control lines are closely spaced with lines carrying large currents, the coupling of magnetic fields can also occur. Use shielded cables to help minimize noise. Potential noise generators include switching components relays, solenoids, motors, and motor starters.

Refer to the relevant Federal, State, Provincial, and local electric codes that provide data such as the size and types of conductors, color codes and connections necessary for safe grounding of electrical components. It is recommended that the high voltage and low voltage cabling be separated and dressed apart. In particular, the AC cables and switch wiring should not be in the same conduit with all communication cables.

Line Voltage Variation

The unit's power supply is built to operate with input voltage ranges of 100-240 VAC with an AC power supply, and still allow the system to function within its operating margin. As long as the incoming voltage is adequate, the power supply provides all the logic voltages necessary to support the processor, memory, and I/O.

In cases in which the installation is subject to unusual AC line variations, use a constant voltage transformer to prevent the system from shutting down too often. However, a first step toward the solution of the line variations is to correct any possible feed problem in the distribution system. If this correction does not solve the problem, use a constant voltage transformer.

The constant voltage transformer stabilizes the input voltage to the 1600 by compensating for voltage changes at the primary in order to maintain a steady voltage at the secondary. When using a constant voltage transformer, check that the power rating is sufficient to supply the 1600.

Safety Agency Approval

The Xycom 1600 is UL approved to meet the following standards:

- Canadian Standards Association, Specification C22.2 No. 950 Information Technology Equipment (cUL Listed, File E181675)
- *Underwriters Laboratories Standard UL 60950* Information Technology Equipment (UL Listed, File E181675)

Installing Options

Warning

This should be done by qualified service personnel only.

Caution

Turn off the unit before installing internal hardware.

Additional DDR SDRAM Dual In-Line Memory Modules (DIMMs)

The 1600 CPU can be ordered with 184-pin DDR SDRAM options up to 1 GB (512 MB on Windows 95 and 98). This configuration supports the DDR 200/266. To reconfigure the SDRAM capacity, change the SDRAM DIMMs on the motherboard.

Adding 5.25” and 3.5” Devices

1. Turn off power to the unit and unplug the power cord on the rear of the 1600.
2. Open the 1600 unit by removing the three screws from the top cover (see Figure 2-12).

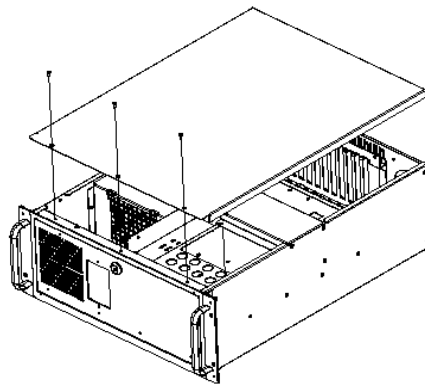

Figure 2-12. Removing the Top Cover

3. Unscrew and remove the hold-down bar from the unit (see Figure 2-15).
4. Remove the device and power cables if they are connected to existing devices.
5. Remove the screws securing the 5.25” or 3.5” drive bay to the front panel.
6. Slide the 5.25” or 3.5” drive bay approximately 1 inch towards the back of the chassis.
7. Lift the drive bay up and remove it from the unit. See Figures 2-13 and 2-14.

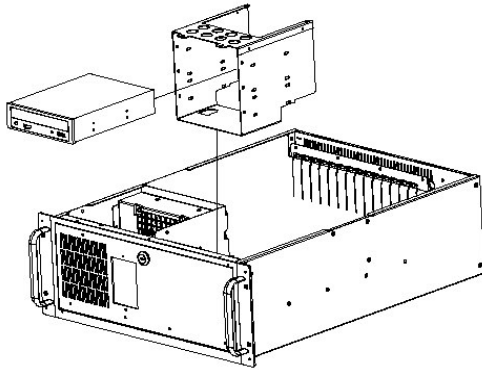

Figure 2-13. Installing a 5.25" Device

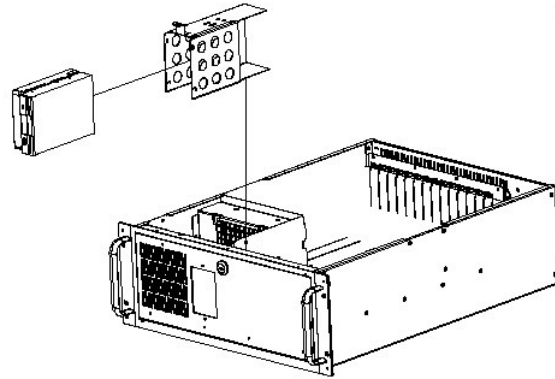

Figure 2-14. Installing a 3.5" Device

8. Add or replace the 5.25" or 3.5" device to the drive bay and secure with the screws.
9. Make the appropriate power and IDE or floppy data cable connections.
10. Replace the hold-down bar and then close the unit.

ISA/PCI Expansion

The following instructions describe the installation of ISA or PCI expansion boards.

Warning

The maximum power available for ISA and/or PCI boards is 150W.

1. Turn off power to the unit and unplug the power cord on the rear of the 1600.
2. Open the 1600 unit by removing the three screws from the top cover (see Figure 2-5).
3. Remove the two screws from the hold down bracket and remove the hold down bracket (see Figure 2-8).
4. Remove the screw and the retaining bracket from the desired track.
5. Slide the ISA or PCI expansion board into the desired slot.

Caution

Do not force the boards or apply uneven pressure.

6. Push the board into the backplane connectors.

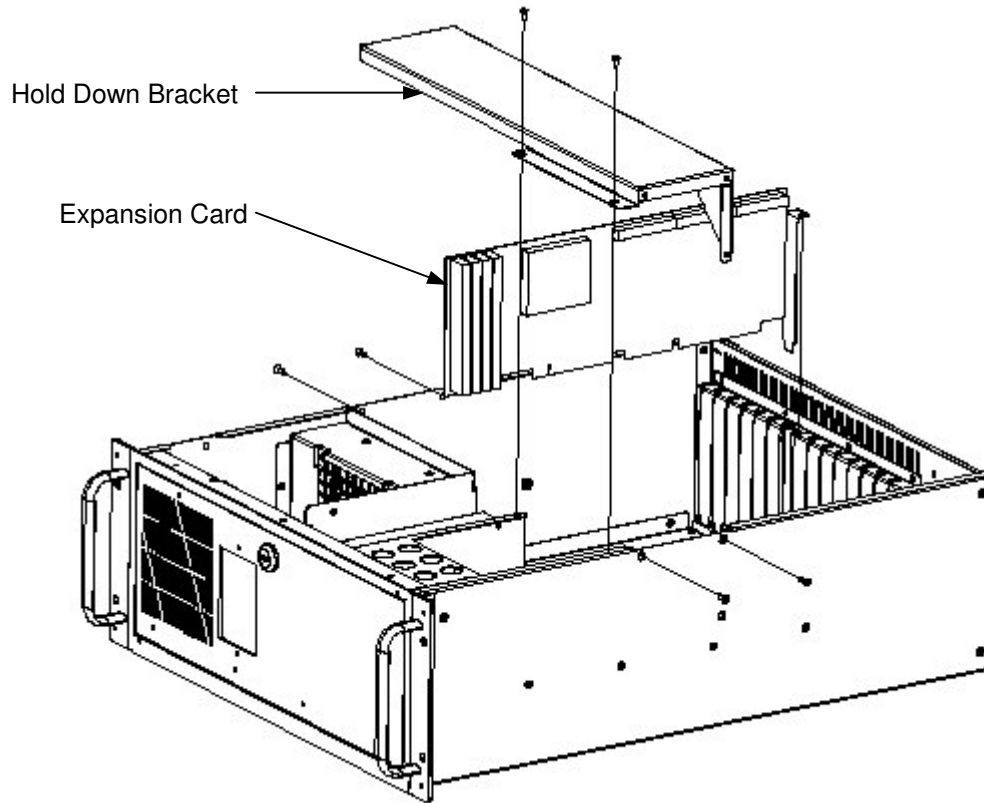

Figure 2-15. Installing ISA or PCI Boards

7. Reinstall the hold down bracket (foam side down) with two screws.
8. Secure the board by installing the screw through the hole in the board's metal retaining bracket and into the top of the track.
9. Replace the top cover.

Custom Logo

You have the option to place a custom label on your unit. Refer to Figure 2-16 for the dimensions and recommended requirements for a customized label. Once a customized label is procured, place the new label over the “Xycom Automation – Pro-face” label.



Figure 2-16. Customized Label Dimensions

Chapter 3 – SBC-860 P4 Board & BIOS Setup

SBC-860 P4 Motherboard

This section outlines the features of the SBC-860 P4 motherboard, includes a mechanical drawing, illustrates the jumper settings and connector pinouts, and explains the BIOS CMOS setups. For more information about the watchdog timer, see Appendix B – Programming the SBC-860 Watchdog Timer.

Features

The SBC-860 P4 Motherboard offers the following features:

- **Processor** – 2 GHz Pentium® 4 Processor in the 478 pin package (with system bus frequencies of 400/533MHz)
- **System Memory** - 184-pin DDR SDRAM DIMM x 2, maximum 1 GB (512 MB on Windows 95 and 98), supports DDR 200/266
- **Chipset** - Intel® 82845 GV, Intel® 82801DB(ICH4)
- **I/O Chipset** - ITE 8712
- **USB** - Two USB 2.0 ports
- **BIOS** - Award 4Mb FLASH BIOS
- **Ethernet** - 10/100Base-Tx RJ-45 connector x 2
- **IDE Support** - Two IDE connectors, which accept up to 4 devices, supporting Ultra DMA 100
- **Watchdog timer*** - Can generate a system reset. Software selectable time-out interval (1sec.~255sec. 1sec/step; 1min.~254min. 1min/step)
- **Display Memory size** - Shared memory up to 8MB with Dynamic Video Memory Technology (up to 1600 x 1200@ 24bpp colors for CRT)
- **Audio** - Intel® 82801DB(ICH4), ALC201 CODEC (not supported by MS-DOS)

**see Appendix B for more information on the watchdog timer.*

Mechanical Drawing

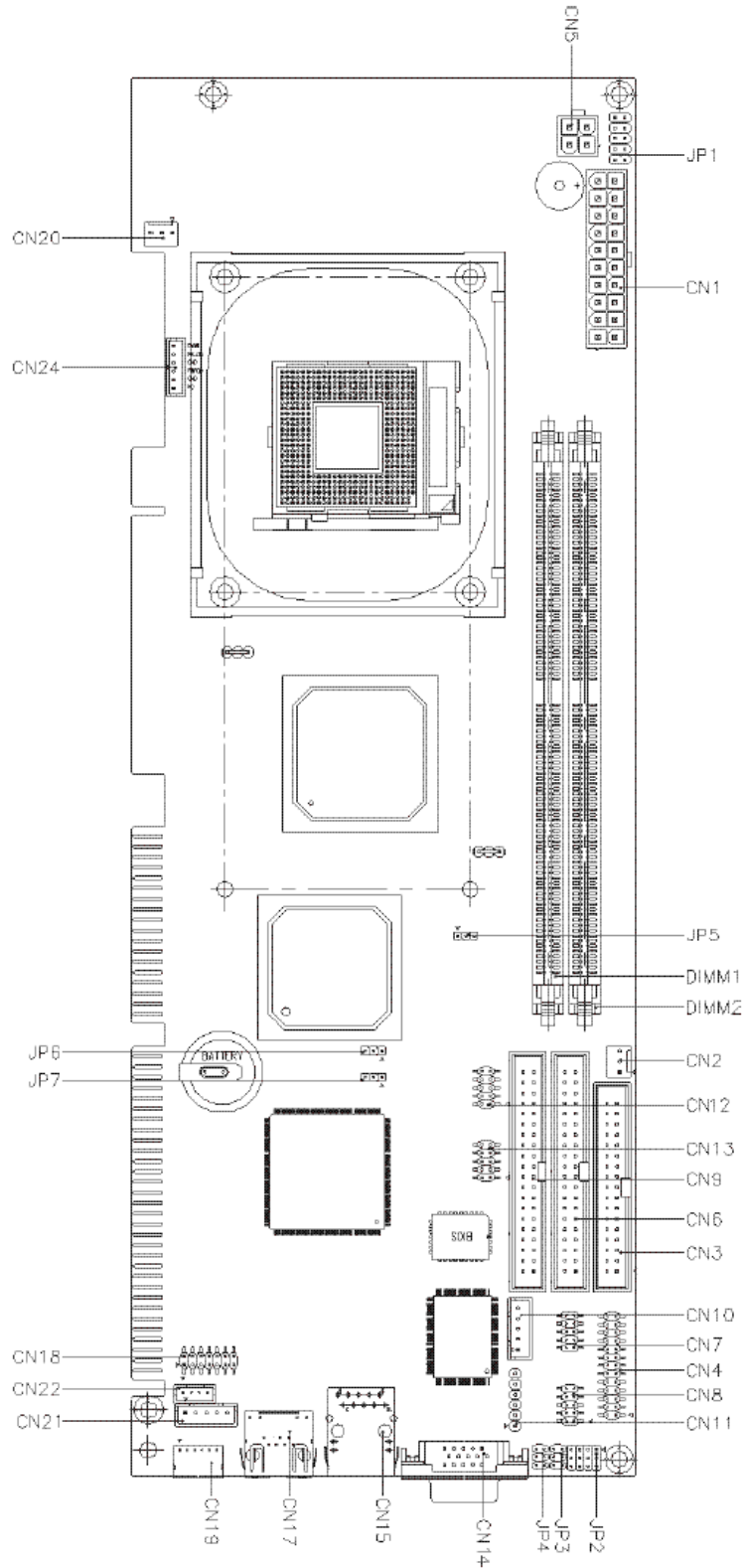

Figure 3-1. SBC-860 Motherboard

Jumper Settings

Following are diagrams of the jumper settings for the COM2 connectors. Refer to Figure 3-1 for a mechanical drawing showing all of the jumpers.

Front Panel (JP1)

Table 3-1. Front Panel (JP1)

Pin	Signal
1-2	ATX Power-on Button
3-4	HDD Active LED
5-6	External Speaker
7-8	Power LED
9-10	System Reset Button

COM2 RS-232/422/485 Selection – 1 (JP2)

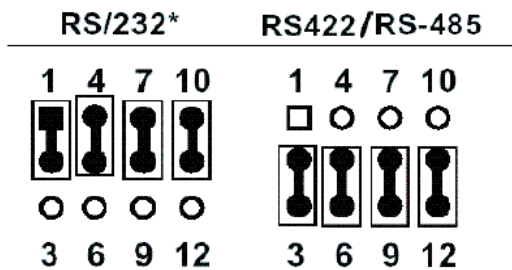

* Default

COM2 RI/+5V/+12V Selection (JP3)

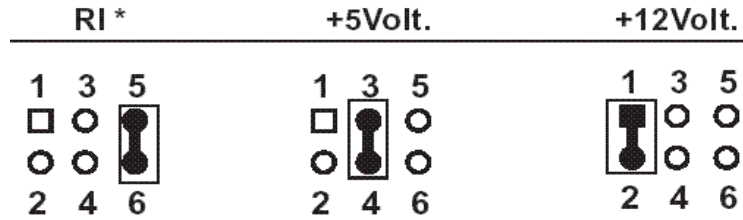

* Default

COM2 RS-232/422/485 Selection – 2 (JP4)

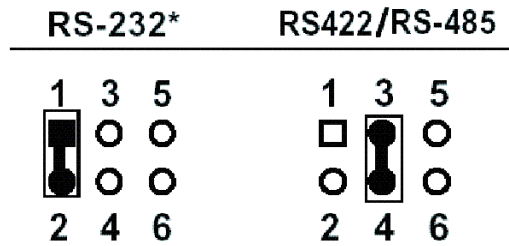

* Default

Clear CMOS (JP6)



* Default

Watch Dog Timer (JP7)



*Default

Connector Pinouts

The following sections describe the pinouts for the floppy drive connector, COM1, COM2, power connector, primary and secondary hard drive connectors, VGA, and parallel port connectors. Refer to Figure 3-1 on the previous page for a mechanical drawing showing all jumpers and connectors.

Floppy Drive Connector (CN3)

The following table lists the signal definitions for the DB-34 floppy drive connectors.

Table 3-2 Floppy Drive Pinout

Pin	Signal	Pin	Signal
1	Ground	2	DENSEL#
3	Ground	4	N/C
5	Ground	6	N/C
7	Ground	8	INDEX#
9	Ground	10	MTRA#
11	Ground	12	DRVB#
13	Ground	14	DRVA#
15	Ground	16	MTRB#
17	Ground	18	DIR#
19	Ground	20	STEP#
21	Ground	22	WDATA#
23	Ground	24	WGATE#
25	Ground	26	TRK0#
27	Ground	28	WPT#
29	N/C	30	RDATA#
31	Ground	32	HDSEL#
33	N/C	34	DSKCHG#

Parallel Port Connector – LPT1 (CN4)

The parallel port connector is located on the CPU board. The following table shows the signal definitions for the DB-26 LPT1 connector.

Table 3-3. Parallel Port Pinout

Pin	Signal	Pin	Signal
1	STROBE	2	AUTOFEED
3	PD0	4	PERROR
5	PD1	6	INIT
7	PD2	8	SELIN
9	PD3	10	GND
11	PD4	12	GND
13	PD5	14	GND
15	PD6	16	GND
17	PD7	18	GND
19	PACK	20	GND
21	PBUSY	22	GND
23	PE	24	GND
25	SELECT	26	N/C

ATX PWM4P Power Connector (CN5)

The following table lists the signal definitions for the DB-4 power connector.

Table 3-4 Power Control Pinout

Pin	Signal
1	Ground
2	Ground
3	+ 12 Volt.
4	+12 Volt.

COM1 Serial Port Connector (CN8)

The COM1 serial port supports RS-232 mode, which allows you to connect to a serial device. This port is located on the I/O side of the unit. The following table lists the signal definitions for the COM1 DB-10 connectors.

Table 3-5. COM1 Serial Port Pinout

Pin	Signal	Pin	Signal
1	DCD	2	RXD
3	TXA	4	DTR
5	GND	6	DSR
7	RTS	8	CTS
9	RI	10	N/C

Primary IDE Hard Drive Connector (CN6)

The following table lists the signal definitions for the IDE DB-40 connectors

Table 3-6. Primary IDE Connector

Pin	Signal	Pin	Signal
1	PRI_IDERST#	2	Ground
3	PDD7	4	PDD8
5	PDD6	6	PDD9
7	PDD5	8	PDD10
9	PDD4	10	PDD11
11	PDD3	12	PDD12
13	PDD2	14	PDD13
15	PDD1	16	PDD14
17	PDD0	18	PDD15
19	Ground	20	N/C
21	PDREQ	22	Ground
23	PDIOW#	24	Ground
25	PDIOR#	26	Ground
27	DIORDY	28	Ground
29	PDDACK#	30	Ground
31	IRQ14	32	N/C
33	PDA1	34	P66DET
35	PDA0	36	PDA2
37	PDCS#1	38	PDCS#3
39	IDACTP#	40	Ground

COM2 Serial Port Connector (CN7)

COM2 supports RS-232/422/485 mode, allowing you to connect serial devices. This port is located on the I/O side of the unit. The following table lists the signal definitions for the COM2 DB-10 connectors.

Table 3-7. COM2 Serial Port Pinout

Pin	RS-232 Mode	RS-422 Mode	RS-485 Mode
1	DCD	TXD-	TXD-
2	RXD	RXD+	RXD+
3	TXD	TXD+	TXD+
4	DTR	RXD-	RXD-
5	GND	N/C	N/C
6	DSR	N/C	N/C
7	RTS	N/C	N/C
8	CTS	N/C	N/C
9	RI	GND	GND
10	N/C	N/C	N/C

Secondary IDE Hard Drive Connector (CN9)

The following table lists the signal definitions for the secondary IDE DB-40 connector.

Table 3-8

Pin	Signal	Pin	Signal
1	SEC_IDERST#	2	Ground
3	SDD7	4	SDD8
5	SDD6	6	SDD9
7	SDD5	8	SDD10
9	SDD4	10	SDD11
11	SDD3	12	SDD12
13	SDD2	14	SDD13
15	SDD1	16	SDD14
17	SDD0	18	SDD15
19	Ground	20	N/C
21	SDREQ	22	Ground
23	SDIOW#	24	Ground
25	SDIOR#	26	Ground
27	SIORDY	28	Ground
29	SDDACK#	30	Ground
31	IRQ15	32	N/C
33	SDA1	34	S66DET
35	SDA0	36	SDA2
37	SDCS#1	38	SDCS#3
39	IDEACTS#	40	Ground

USB 2.0 Port 1 Connector (CN13)

The following table lists the signal definitions for the USB connector.

Table 3-9. USB 2.0 Port 1 Pinout

Pin	Signal	Pin	Signal
1	USBVDD0-1	2	USB GND
3	USBD0-	4	USB GND
5	USBD0+	6	USBD1+
7	USB GND	8	USBD1-
9	USB GND	10	USBVDD0-1

VGA Connector (CN14)

The VGA connector is located on the CPU board. The following table lists the signal definitions for the VGA DB-15 connector.

Table 3-10. VGA Pinout

Pin	Signal	Pin	Signal
1	CRT_RED	9	5 Volt.
2	CRT_GREEN	10	VGA GND
3	CRT_BLUE	11	N/C
4	N/C	12	CRT_SDA
5	VGA GND	13	CRT_HSYNC
6	VGA GND	14	CRT_VSYNC
7	VGA GND	15	CRT_VSYNC
8	VGA GND		

LAN RJ45 Connector (CN15 and CN17)

The following table lists the signal definitions for the LAN RJ45 DB-8 connector.

Table 3-11. LAN RJ45 Pinout

Pin	Description
1	TX+
2	TX-
3	RX+
4	N/C
5	N/C
6	RX-
7	N/C
8	N/C

Audio Input/Output Connector (CN18)

The following table lists the signal definitions for the Audio DB-14 connector.

Table 3-12. Audio Connector pinout

Pin	Signal	Pin	Signal
1	MIC_in	2	MIC_Vcc
3	GND	4	CD_GND
5	LINE_in L	6	CD_in L
7	LINE_in R	8	CD_GND
9	GND	10	CD_in R
11	LINE_out L	12	LINE_out R
13	GND	14	GND

PS/2 Combined Keyboard and Mouse Connector (CN19)

The following table lists the signal definitions for the PS/2 DB-6 connector.

Table 3-13. PS/2 Keyboard and Mouse Pinout

Pin	Signal	Pin	Signal
1	Mouse Clock	2	Keyboard Clock
3	Vcc	4	GND
5	Keyboard Data	6	Mouse Data

Internal Keyboard Connector (CN21)

The following table lists the signal definitions for the internal keyboard DB-5 connector.

Table 3-14. Front keyboard connector

Pin	Signal
1	Keyboard clock
2	Keyboard data
3	N/C
4	Ground
5	Vcc

Internal Mouse Connector (CN22)

The following table lists the signal definitions for the internal mouse DB-4 connector.

Table 3-15. Front mouse connector

Pin	Signal
1	Mouse clock
2	Mouse data
3	Ground
4	Vcc

Award BIOS CMOS Setup

Award's BIOS ROM has a built-in Setup program that allows users to modify the basic system configuration. This type of information is stored in battery-backed CMOS memory so that it retains the Setup information when the power is turned off.

Some items in the BIOS are programmed to auto detect your system. The presence or the values of these items vary with the corresponding hardware specification of your system. Table 3-16 describes different Setup menu options.

Note

Some units do not support all the options shown on the following screens. If a setting is not displayed, your unit does not have that particular capability.

Table 3-16. BIOS CMOS Setup

Setup Menu	Description
Entering Setup	Power on the computer and press immediately. This will allow you to enter Setup. The top menu offers users various functions to configure the system. The default page after entering the BIOS setup is [Main - Standard CMOS setup].
Major Setup Features Main/Standard CMOS Features	Use this menu for basic system configuration (Date, time, IDE, etc.)
Advanced Features Setup Advanced BIOS Features Advanced Chipset Features Integrated Peripherals Power Management Setup PnP / PCI Configurations	Use this menu to set the advanced features available on your system. Use this menu to change the values of the chipset registers and optimize your system performance. Use this menu to specify your settings for integrated peripherals. (USB, Serial port, Parallel port, keyboard, mouse etc.) Use this menu to specify your settings for power management. (HDD power down, power on by events, KB wake up, etc.) This entry appears if your system supports PnP/PCI.
Default -Load Optimized Defaults Security -Set/Change Password	Use this menu to load the BIOS default values that are factory settings for optimal performance system operations. While AWARD has designated the custom BIOS to maximize performance, the factory has the right to change these defaults to meet their needs. Use this menu to set Supervisor/User Passwords.
Clk/Voltage Setup	Use this menu to specify your settings for auto detect DI:MJ,1/PCI clock and spread spectrum.
PC Health Setup	This menu allows you to set the shutdown temperature for your system.
Save and Exit Setup	Save CMOS value changes to CMOS and exit setup
Exit Without Saving	Abandon all CMOS value changes and exit setup

Standard CMOS Setup

Select Main from the top menu to access the Standard CMOS Setup option. A screen similar to the one shown below is displayed. This Standard Setup Menu allows users to configure system components such as date, time, hard disk drive, floppy drive and display. Once a field is highlighted, on-line help information is displayed in the right box of the Menu screen. Table 3-17 describes the menu fields.

Phoenix – Award BIOS CMOS Setup Utility		
Main	Advanced	Defaults Security PC Health Clk/Voltage Exit
Date (mm:dd:yy)	Wed, Aug 20 2003	Item Help
Time (hh:mm:ss)	10:23:42	
▶ IDE Primary Master		Menu Level ▶ Change the day, month, year and century
▶ IDE Primary Slave		
▶ IDE Secondary Master		
▶ IDE Secondary Slave		
Drive A	[1.44M, 3.5 in]	
Drive B	[None]	
Video	[EGA/VGA]	
Halt On	(All, but Keyboard)	
Base Memory	640K	
Extended Memory	64512K	
Total Memory	65535	
↑↓→←: Move Enter: Select +/-/PU/PD: Value F10: Save ESC: Exit F1: General Help F5: Previous Values F7: Optimized Defaults F9: Menu		

Figure 3-2. Standard CMOS Setup Menu

Table 3-17. Standard CMOS Setup Menu Options

Menu Field	Description												
Date and Time Configuration	<p>The BIOS determines the day of the week from the other date information. This field is for information only. Press the left or right arrow key to move to the desired field (date, month, year). Press the PgUp/ - or PgDn/ + key to change the setting, or simply type the desired value into the field.</p> <p>The time format is based on the 24-hour military-time clock. For example, 1 p.m. is 13:00:00 hours. Press the left or right arrow key to move to the desired field. Press the PgUp / - or PgDn/ + key to change the setting, or simply type the desired value into the field.</p>												
<p>IDE Primary/Secondary Master/Slave</p> <p style="text-align: center;">IDE HDD Auto-Detection</p> <p style="text-align: center;">IDE Primary/Secondary Master/Slave</p> <p style="text-align: center;">Drive A & Drive B</p>	<p>This section does not show information about other IDE devices, such as a CD-ROM drive, or other hard drive types, such as SCSI drives.</p> <p>NOTE: We recommend that you select type AUTO for all drives.</p> <p>The BIOS can automatically detect the specifications and optimal operating mode of almost all IDE hard drives. When you select AUTO for a hard drive, the BIOS will detect its specifications</p> <p>If you do not want to select "AUTO", other methods of selecting the drive type are available:</p> <ol style="list-style-type: none"> 1.NONE: No drive type to be selected. 2.Manual: This will allow you to manually set the drive type you are using in your system. (See below) <p>Select the correct specifications for the diskette drive(s) installed in the computer:</p> <table> <tbody> <tr> <td>None</td> <td>No diskette drive installed</td> </tr> <tr> <td>360K, 5.25 in</td> <td>5-1/4 inch PC-type standarddrive; 360Kbyte capacity</td> </tr> <tr> <td>1.2M, 5.25 in</td> <td>5-1/4 inch AT-type high density drive; 720Kbyte capacity</td> </tr> <tr> <td>720K, 3.5 in</td> <td>3-1/2 inch double sided drive; 360Kbyte capacity</td> </tr> <tr> <td>1.44M, 3.5 in</td> <td>3-1/2 inch double sided drive; 1.44Mbyte capacity</td> </tr> <tr> <td>2.88, 3.5 in</td> <td>3-1/2 inch double sided drive; 2.88Mbyte capacity</td> </tr> </tbody> </table>	None	No diskette drive installed	360K, 5.25 in	5-1/4 inch PC-type standarddrive; 360Kbyte capacity	1.2M, 5.25 in	5-1/4 inch AT-type high density drive; 720Kbyte capacity	720K, 3.5 in	3-1/2 inch double sided drive; 360Kbyte capacity	1.44M, 3.5 in	3-1/2 inch double sided drive; 1.44Mbyte capacity	2.88, 3.5 in	3-1/2 inch double sided drive; 2.88Mbyte capacity
None	No diskette drive installed												
360K, 5.25 in	5-1/4 inch PC-type standarddrive; 360Kbyte capacity												
1.2M, 5.25 in	5-1/4 inch AT-type high density drive; 720Kbyte capacity												
720K, 3.5 in	3-1/2 inch double sided drive; 360Kbyte capacity												
1.44M, 3.5 in	3-1/2 inch double sided drive; 1.44Mbyte capacity												
2.88, 3.5 in	3-1/2 inch double sided drive; 2.88Mbyte capacity												
Video	<p>This function setting allows you to select the video type.</p> <p>The choices are: EGA/VGA, CGA 40, CGA 80, and MONO</p>												
Halt On	<p>During the Power-On Self-Test (POST), the computer will stop if the BIOS detects a hardware error. You can tell the BIOS to ignore certain errors during POST and continue the boot-up process.</p> <p>The choices are:</p> <ul style="list-style-type: none"> <i>All, But Keyboard;</i> <i>All, But Diskette;</i> <i>All, But Disk/Key;</i> <i>All Errors;</i> <i>No Errors.</i> 												
Base Memory	Typically 640 KB. Also called conventional memory. The DOS operating system and conventional applications use this area.												
Extended Memory	Above the 1 MB boundary. Early IBM personal computers could not use memory above 1 MB, but current PCs and their software can use extended memory.												
Total Memory	The fields show the total installed random access memory (RAM).												

Advanced BIOS Features Setup

Enter the Advanced BIOS Features Setup by choosing the Advanced option from the top menu. The following screen will be displayed. Table 3-18 describes the menu fields.

Phoenix – Award BIOS CMOS Setup Utility		
Main	Advanced	Defaults Security PC Health Clk/Voltage Exit
Virus Warning	[Disabled]	Item Help
Hyper-Threading Technology	[Enabled]	
Quick Power-On Self-Test	[Enabled]	Menu Level ►► Allows you to choose the VIRUS warning feature for IDE Hard disk boot sector protection. If this function is enabled and someone attempts to write data into this area, BIOS will show a warning message on the screen and alarm will beep.
First Boot Device	[Floppy]	
Second Boot Device	[HDD]	
Third Boot Device	[CDROM]	
Boot Other Device	[Enabled]	
Swap Floppy Drive	[Disabled]	
Boot Up Floppy Seek	[Enabled]	
Boot Up NumLock Status	[On]	
Gate A20 Option	[Fast]	
X Typematic Rate Setting	[Disabled]	
X Typematic Rate (Chars/Sec)	[6]	
Typematic Delay (msec)	[250]	
Security Option	[Setup]	
APIC Mode	[Enabled]	
Silent POST	[Enabled]	
↑↓→←: Move Enter: Select +/-/PU/PD: Value F10: Save ESC: Exit F1: General Help F5: Previous Values F7:Optimized Defaults F9: Menu		

Figure 3-3. Advanced BIOS Features Menu

Note

Hyper-Threading Technology is only supported by Intel processors that are designed to interface with that technology. If your Intel processor does not support this technology, the Hyper-Threading Technology option will not appear in this BIOS screen.

Table 3-18. Advanced BIOS Features Menu Options

Menu Field	Description
Virus Warning	<p>When enabling this item, you receive a warning message if a program (specifically a virus) attempts to write to the boot sector or the partition table of the hard disk drive. If you receive a warning message, you should run an anti-virus program. However, this feature protects only the boot sector, not the entire hard drive.</p> <p>NOTE: Many disk diagnostic programs that access the boot sector table can trigger the virus warning message. If you plan to run such a program, we recommend that you first disable the virus warning. Before installing Microsoft Windows, please disable this function.</p> <p>The choices: Enabled and Disabled.</p>
Hyper Threading Technology	<p>If your Pentium 4 processor supports this function, you can select Enabled for Windows XP and Linux 2.4x as optimized for Hyper Threading Technology. Select Disabled for other OSs which do not optimize for Hyper Threading Technology. If your processor can't support this function, this item will be hidden.</p> <p>The choices: Enabled and Disabled</p>
Quick Power-On Self-Test	<p>Select Enabled to reduce the amount of time required to run the Power-On Self-Test (POST) while system is booting.</p> <p>The choices: Enabled and Disabled</p>
First/Second/Third Boot Device	<p>The BIOS attempts to load the operating system and the devices in the sequence selected in these items.</p> <p>The choices: Floppy, LS120, HDD, SCSI, CDROM, ZIPIOO, USB-FDD, USB-ZIP, USB-CDROM, USB-HDD, LAN, ISA-FDD, and Disabled</p>
Boot Other Device	<p>If your boot device, such as SCSI/RAID, is not included in the following choices you may set First/Second/Third Boot devices to "Disabled" and enable the BOOT Other Device function. The system will automatically boot the other device. The choices are: Floppy; LS120; HDD; SCSI; CDROM; Z1P100; USB-FDD; USB-ZIP; USB-CDROM; USB-HDD; LAN; ISA-FDD.</p> <p>The choices: Enabled and Disabled</p>
Swap Floppy Drive	<p>This field is effective only in systems with two floppy drives. Selecting Enabled assigns physical drive B to logical drive A, and vice-versa.</p> <p>The choices: Enabled and Disabled</p>
Boot-Up Floppy Seek	<p>When Enabled, the BIOS tests (seeks) floppy drives to determine whether they have 40 or 80 tracks. Only 360 KB floppy drives have 40 tracks; drives with 720 KB, 1.2 MB, and 1.44 MB capacity all have 80 tracks. Because very few modem PCs have 40-track floppy drives, we recommend you to choose "Disabled" to save time during boot-up.</p> <p>The choices: Enabled and Disabled</p>
Boot-Up NumLock Status	<p>Toggle between On or Off to control the state of the NumLock key when the system boots. When toggled On, the numeric keypad generates numbers instead of controlling cursor operations.</p> <p>The choices: On and Off.</p>
Gate A20 Option	<p>Gate A20 refers to the way the system addresses memory above 1 MB (i.e. extended memory). When set to Fast, the system chipset controls Gate A20. When set to Normal, a pin in the keyboard controller controls Gate A20. Setting Gate A20 to fast improves system speed, particularly with OS/2 and Windows.</p> <p>The choices: Fast and Normal</p>

Table 3-18. Advanced BIOS Features Menu Options

Menu Field	Description
Typematic Rate Setting	Keystrokes repeat at a rate determined by the keyboard controller. When enabled, the typematic rate and typematic delay can be selected. The choices: Enabled and Disabled
Typematic Rate	When the typematic rate setting is Enabled, you can select the rate at which character repeats when you hold down a key. The choices: 6, 8, 10, 12, 15, 20, 24, and 30.
Typematic Delay	When the typematic rate setting is Enabled, you can select the delay before keystrokes begin to repeat. The choices: 250, 500, 750, and 1000 (msec).
Security Option	If you have set a password, select whether the password is required every time the System boots, or only when you enter Setup. The choices: Setup and System.
APIC Mode	Advanced programmable interrupt controller (APIC) mode can be used for either a uni-processor or multi-processor. The choices: Enabled and Disabled
Silent POST	This feature allows you to enable the system to show the company's logo when the power is on. The choices: Enabled and Disabled

Advanced Chipset Features Setup

By choosing the Advanced Chipset Features Setup option from the Advanced menu, the following screen is displayed. Table 3-19 describes the Advanced Chipset menu fields.

Phoenix – Award BIOS CMOS Setup Utility		
Main Advanced Defaults Security PC Health Clk/Voltage Exit		
Advanced Chipset Features		Item Help
DRAM Timing Selectable	[By SPD]	Menu Level ►►
X CAS Latency Time	[1, 5]	
X Active to Precharge Delay	[7]	
X DRAM RAS# to CAS# Delay	[3]	
X DRAM RAS# Precharge	[3]	
Memory Frequency For	[Auto]	
System BIOS Cacheable	[Enabled]	
Video BIOS Cacheable	[Disabled]	
Memory Hole At 15M – 16M	[Disabled]	
AGP Aperture Size (MB)	[64]	
** On-Chip VGA Setting **		
On-Chip Frame Buffer Size	[8MB]	
↑↓→←: Move Enter: Select +/-/PU/PD: Value F10: Save ESC: Exit F1: General Help F5: Previous Values F7: Optimized Defaults F9: Menu		

Figure 3-4. Advanced Chipset Features Menu

Table 3-19. Advanced Chipset Features Menu Options

Menu Field	Description
DRAM Timing Selectable	This function stores information about Memory Module setting. Therefore, it can automatically detect the best frequency at which the memory module should use. The Choices: By SPD and Manual
CAS Latency Time ¹	When synchronous DRAM is installed, the number of clock cycles of CAS latency depends on the DRAM timing. Do not reset this field from the default value specified by the system designer. The values of the choice may vary with different RAM types. The choices: 1.5, 2, 2.5, and 3
Active to Pre charge Delay ¹	This function identifies the minimum time from active to pre-charge. The choices: 5, 6, and 7
DRAM RAS# to CAS# Delay ¹	This function controls the number of clocks that are inserted between a row activate command and a read or write command to that row. The choices: 2 and 3
DRAM RAS# Precharge ¹	This function controls the number of clocks that are inserted between a row precharge command and an active command to the same row. The choices: 2 and 3
Memory Frequency For	This item allows you to select the memory frequency. The choices: Auto, DDR200, and DDR266
System BIOS Cacheable	Selecting Enabled allows caching of the system BIOS ROM at f0000h-FFFFFh, resulting in better system performance. The choices: Enabled and Disabled
Video BIOS Cacheable	Selecting Enabled allows caching of the video BIOS ROM at C0000-C8000, resulting in better video performance. The choices: Enabled and Disabled
Memory Hole At 15M-16M	Enable this function to allow ISA ROM to map to 15-16M and support legacy ISA devices. If you don't utilize legacy ISA devices in your system, you are recommended to disable this function to enhance graphic performance. The choices: Enabled and Disabled
AGP Aperture Size (MB)	Aperture size will ensure that all writes posted in the global write buffer to the graphics aperture are retired to DRAM before initiating any CPU-PCI cycle. This can be used to ensure synchronization between the CPU and AGP master. The choices: 4,8, 16,32, 64, 128, and 256
On Chip VGA Setting * On-Chip Frame Buffer Size	This function is used to select the amount of main memory that is pre-allocated to support the internal graphics device. The choices: 1MB and 8MB

¹ These fields are only editable when the DRAM timing selectable is set to manual. If the DRAM timing selectable is not set to manual, the fields automatically change based on RAM type.

Integrated Peripherals

By choosing the Integrated Peripherals option from the Advanced menu, the following screen is displayed. Table 3-20 describes the Integrated Peripherals menu fields.

Phoenix – Award BIOS CMOS Setup Utility		
Main	Advanced	Defaults Security PC Health Clk/Voltage Exit
Integrated Peripherals		
IDE DMA transfer access	[Enabled]	↑
On-Chip Primary PCI IDE	[Enabled]	
IDE Primary Master PIO	[Auto]	
IDE Primary Slave PIO	[Auto]	
IDE Primary Master UDMA	[Auto]	
IDE Primary Slave UDMA	[Auto]	
On-Chip Secondary PCI IDE	[Enabled]	
IDE Secondary Master PIO	[Auto]	
IDE Secondary Slave PIO	[Auto]	
IDE Secondary Master UDMA	[Auto]	
IDE Secondary Slave UDMA	[Auto]	Item Help
USB Controller	[Enabled]	
USB 2.0 Controller	[Enabled]	
USB Keyboard Support	[Disabled]	
USB Mouse Support	[Disabled]	
Onboard Audio	[Enabled]	
Onboard LAN 1	[Enabled]	
		Menu Level

(continued on next page)

Onboard LAN2	[Enabled]	
Init Display First	[Onboard/AGP]	
IDE HDD Block Mode	[Enabled]	
Power-on Function	[Any key]	
KB Power-on Password	[]	
Hot Key Power-on	[Ctrl-F1]	
Onboard FDC Controller	[Enabled]	
Onboard Serial Port 1/2	[Auto]	
UART Mode Select	[Disabled]	
UR2 Duplex Mode	[Full]	
Onboard Parallel Port	[Disabled]	
Parallel Port Mode	[SPP]	
ECP Mode Use DMA	[1]	
↑↓→←: Move Enter: Select +/-/PU/PD: Value F10: Save ESC: Exit F1: General Help F5: Previous Values F7: Optimized Defaults F9: Menu		

Figure 3-5. Integrated Peripherals Menu

Note

The lower portion of Table 3-5 shows the options that appear when you scroll down through the menu.

Table 3-20. Integrated Peripherals Menu Options

Menu Field	Description
IDE DMA transfer access	This function is used to Enable or Disable IDE DMA transfer in DOS mode. The choices: Enabled and Disabled
On-Chip Primary Secondary PCI IDE	The integrated peripheral controller contains an IDE interface with support for two IDE channels. Select Enabled to activate each channel separately. The choices: Disabled and Enabled
IDE Primary or Secondary Master/Slave PIO	The four IDE PIO (Programmable Input/Output) fields let you set a PIO mode (0-1) for each of the two IDE devices and the two storage devices that the onboard IDE interface supports. Modes 0 through 4 provide successively increased performance. In Auto mode, the system automatically chooses the best mode for each device. The choices: Auto, Mode 0, Mode 1, Mode 2, Mode 3, and Mode 4.
IDE Primary or Secondary Master/Slave UDMA	Ultra DMA100 implementation is possible only if your IDE hard drive supports it and the operating environment includes a DMA driver. If both your hard drive and IDE cable support Ultra DMA 100, select Auto to enable BIOS support. The choices: Auto and Disabled
USB Controller	This function is used to Enable or Disable onboard USB controller The choices: Enabled and Disabled
USB 2.0 Controller	This function is used to Enable or Disable high speed USB 2.0 device The choices: Enabled and Disabled
USB Keyboard/Mouse Support	Select Enabled when you use a Universal Serial Bus (USB) keyboard or mouse under DOS mode. The choices: Enabled and Disabled
Onboard Audio/LAN 1/LAN 2	The default setting for these items are "Enabled". If you don't utilize an onboard LAN/Audio function, select Disabled. This will not have any effect on jumper setting. The choices: Enabled and Disabled
Init Display First	You can select Onboard/ AGP or PCI slot to initialize as the primary display before initializing any other display device on the system. The choices: Onboard/AGP and PCI Slot
IDE HDD Block Mode	Block mode is also called "block transfer", "multiple commands", or "multiple sector read/write". If your IDE hard drive supports block mode (most new drives do), please select "Enabled" for automatic detection of the optimal number of block read/writes per sector the drive can support. The choices: Enabled and Disabled
Power-on Function	Including the power-on switch, all the devices listed below could be defined as power-on methods. Choose any of the following that you care to. The choices: Any key, Button only, Keyboard 98, Password, Hot key, Mouse move, and Mouse click
KB Power-on Password	If you select Password in the power-on function settings, you have to press Enter here to set the password you will use to power-on the system.
Hot key power-on	If you select Hot key as the power-on method, you have to define the Hot key in this section. The choices: Ctrl-F1 thru Ctrl-F12

Table 3-20. Integrated Peripherals Menu Options

Menu Field	Description
Onboard FDC Controller	<p>Select Enabled if your system has a floppy disk controller (FDC) installed on the system board and you wish to use it. If you install an add-in FDC or the system has no floppy drive, select Disabled in this field.</p> <p>The choices: Enabled and Disabled</p>
Onboard Serial Port 1/2	<p>Normally, the board's I/O chips will occupy a certain portion of memory space. For each I/O device the computer provides an I/O address. The more devices that are attached, the more address needed to organize the memory storage areas. Without access to multiple addresses, the system could not handle all of the I/O devices. Also, you will need to select the corresponding interrupt when setting this function.</p> <p>The choices: Disabled, Auto, 2E8/IRQ3, 3E8/IRQ4, 2F8/IRQ3 and 3F8/IRQ4</p>
UART Mode Select	<p>If you don't Disable the Onboard Serial Port 2, you will have to select an operating mode for the second serial port:</p> <p>Normal: RS-232C serial port IrDA: IrDA-compliant serial infrared port ASKIR: Amplitude shift keyed infrared port SCR: Smart Card Reader</p> <p>The choices: Normal, IrDA, ASKIR and SCR</p>
UR2 Duplex Mode	<p>Select the value required by the IR device connected to the IR port. Full-duplex mode permits simultaneous two-direction transmission. Half-duplex mode permits transmission in one direction at a time only.</p> <p>The choices: Half and Full</p>
Onboard Parallel Port	<p>Select a logical LPT port address and corresponding interrupt for the physical parallel port.</p> <p>The choices: Disabled, 378/IRQ7, 278/IRQ5 and 3BC/IRQ7</p>
Parallel Port Mode	<p>There are two bi-directional parallel ports, which supports ECP, EPP, ECP+ EPP, SPP. You must choose the appropriate setting for your system.</p> <p>The choices: SPP, EPP, ECP, and ECP+EP</p>
ECP Mode Use DMA	<p>Select a DMA channel for the port.</p> <p>The choices: 1 and 3.</p>

Power Management Setup

By choosing the Power Management Setup option from the main menu, the following screen is displayed. This sample screen contains the default values for the SBC-860. Table 3-21 describes the menu fields.

Phoenix – Award BIOS CMOS Setup Utility			
Main	Advanced	Defaults Security PC Health Clk/Voltage Exit	
Power Management Setup			
ACPI Function	[Enabled]	↑ ↑ ↑ ↑ ↑ ↑ ↑ ↑ ↑ ↑ ↑ ↓	
ACPI Suspend Type	[Enabled]		
X Run VGABIOS if S3 Resume	[Auto]		
Power Management	[User Define]		
Video Off Method	[DPNS]		
Video Off in Suspend	[Yes]		
Suspend Type	[Stop Grant]		
MODEM Use IRQ	[3]		
Suspend Mode	[Disabled]		
HDD Power Down	[Disabled]		
Soft-Off by PWR-BTTN	[Instant Off]		
Wake-Up by PC Card	[Enabled]		
X USB KB Wake-Up From S3	[Disabled]		
Resume by Alarm	[Disabled]	 	
X Date (of Month) Alarm	0	 	
X Time (hh:mm:dd) Alarm	0 : 0 : 0	 	
Reload Global Timer Events	[Enabled]	 	
↑↓→←: Move Enter: Select +/-/PU/PD: Value F10: Save ESC: Exit F1: General Help F5: Previous Values F7: Optimized Defaults F9: Menu			

Figure 3-6. Power Management Setup Menu

Note

The lower portion of Table 3-6 shows the options that appear when you scroll down through the menu.

Table 3-21. Power Management Setup Menu Options

Menu Field	Description
ACPI Function	This item allows you to Enable or Disable the Advanced Configuration and Power Interface (ACPI). The choices: Enable and Disable
ACPI Suspend Type	This configuration sets the way your system responds to the suspend mode. * S1 (POS): Power-on Suspend * S3 (STR): Suspend to RAM The choices: S1 (POS), S3 (STR), and S1 & S3
Run VGA BIOS if S3 Resume	This feature assigns the OS to either Enable, Disable, or Auto-run the VGA BIOS after resuming from S3 mode. The choices: Yes, No, and Auto
Power Management	Select Max Saving mode or Min Saving mode or define desired Doze Mode, Standby Mode, Suspend Mode, HDD Power Down functions by using the User Defined submenu. Select the type or degree of power saving you desire by choosing on of the following modes: Disable (default) No power Management; disable all four modes Min Power Saving Minimum power management; suspend session after 1 hr, HDD power-down after 15 min Max Power Savings The Maximum power management option is only available for SL CPUs; suspend after 1 to 2 minutes, HDD shutdown after 1 minute User Defined Allows you to set each mode individually. When not disabled, each time range is from 1 min to 1 hr, except for HDD power down, which ranges from 1 min to 15 min
Video Off Method	This determines the manner in which the monitor goes blank. V /H SYNC + Blank This selection will cause the system to turn off the vertical and horizontal synchronization ports and write blanks to the video buffer. DPMS Display power management system. Blank Screen This option only writes blanks to the video buffer.
Video Off In Suspend	After the selected period of system inactivity, the chipset enters hardware suspend mode, stopping the CPU clock and possibly causing other system devices to enter power management modes. In this case, the video hardware can be selected to shut off after a period of system inactivity. This selection determines the manner in which the monitor goes blank. The choices: Yes and No
Suspend Type	This item lets you select two types of suspend. Stop Grant Halts CPU s instruction stream (stop clock) at ACPI C2 state. PwrOn Suspend CPU sleeps at ACPI S1 state. The choices: Stop Grant and PwrOn Suspend
Modem Use IRQ	Choose the interrupt request (IRQ) line assigned to the modem (if any) on your system. Activity of the selected IRQ always awakens the system. The choices: NA, 3, 4, 5, 7, 9, 10, and 11

Table 3-21. Power Management Setup Menu Options

Menu Field	Description
Suspend Mode	Disable this function or select 1 min, 2 min, 4 min, 8 min, 12 min, 20min, 30 min, 40 min, 1 hour. Please refer to the <i>Power Management</i> section for more information
ODD Power Down	Disable this function or select from 1 to 15 minutes. Please refer to <i>Power Management</i> section for more information
Soft-Off by PWR-BTTN	<p>If you select "Instant-Off", pushing the on/off button will instantly shut down the system.</p> <p>If you select "Delay 4 sec", you have to push the on/off button for 4 seconds to shut down the system. In this mode, one touch on the on/off button won't shut down the system but place it in a very low power-usage state, with only enough circuitry receiving power to detect power button activity or Resume by Ring activity.</p> <p>The choices: Instant-Off, Delay 4 Sec</p>
Wake-Up by PCI Card	The choices: Enabled and Disabled
USB KB Wake-Up From S3	The choices: Enabled and Disabled
Resume by Alarm	<p>Enable this item to set up the power up timer.</p> <p>The choices: Enabled and Disabled</p>
Date (of Month) Alarm	
Time (hh:mm:ss) Alarm	
Reload Global Timer Events	<p>When this item is enabled, an event occurring on each listed device resets the global timer to prevent the system from entering Suspend mode. These devices include: Primary/Secondary IDE 1/0, FDD/COM/LPT Port, and PCI PIRQ[A-D]#.</p> <p>The choices: Enabled, Disabled</p>

PnP/PCI Configuration

By choosing the PnP /PCI Configuration option from the top menu, the following screen is displayed. Table 3–14 describes the menu fields.

Phoenix – Award BIOS CMOS Setup Utility		
Main	Advanced	Defaults Security PC Health Clk/Voltage Exit
PnP/PCI Configurations		Item Help
PnP OS Installed	[No]	Menu Level ►► Select Yes if you are using a Plug and Play capable operating system. Select No if you need the BIOS to configure non-boot devices.
Reset Configuration Data	[Disabled]	
Resources Controlled By	[Auto (ESCD)]	
<input checked="" type="checkbox"/> IRQ Resources		
<input checked="" type="checkbox"/> DMA Resources		
PCI/VGA Palette Snoop	[Disabled]	
↑↓→←: Move Enter: Select +/-/PU/PD: Value F10: Save ESC: Exit F1: General Help F5: Previous Values F7:Optimized Defaults F9: Menu		

Figure 3-7. PnP/PCI Configurations Menu

Table 3-22. PnP/PCI Configurations Menu Options

Menu Field	Description
PnP OS Installed	Select Yes if the operating system is Plug and Play-aware, for example Windows® 9x, Windows® 2000, or Windows® XP. Hardware resources will be allocated by the OS. Select No if you need the BIOS to configure non-boot devices. The choices: Yes and No
Reset Configuration Data	Normally, you leave this field disabled. Select enabled to reset Extended System Configuration Data (ESCD) when serious conflict is caused by an add-on device or system reconfiguration. The choices: Enabled and Disabled
Resources Controlled By	The Award Plug and Play BIOS has the capacity to automatically configure all the boot and Plug and Play devices. If you choose Auto, you cannot select IRQ DMA and memory base address fields, since BIOS automatically assigns them. The choices: Auto (ESCD) and Manual
IRQ Resources	When resources are controlled manually, assign each system interrupt a type, depending on the type of device using the interrupt. There are two types to choose from: legacy ISA and PCI/ISA PnP.
Legacy ISA	Devices compliant with the original PC AT bus specification, requiring a specific interrupt (such as IRQ4 for serial port 1)
PCI/ISA PnP	Devices compliant with the Plug and Play standard, whether designed for PCI or ISA bus architecture.
DMA Resources	When resources are controlled manually, assign each DMA channel a type, depending on the type of device using the DMA channel. There are two types for choice: Legacy ISA and PCI/ISA PnP.
Legacy ISA	Devices compliant with the original PC/AT bus specification, requiring a specific DMA channel.
PCI/ISA PnP	Devices compliant with the Plug and Play standard, whether designed for PCI or ISA bus architecture.
PCI/VGA Palette Snoop	Enabling this item informs the PCI/VGA card to keep silent (and to prevent conflict) when palette register is updated (i.e., accepts data without responding any communication signals). This is useful only when two display cards use the same palette address and are plugged into the PCI bus at the same time (such as MPEG or Video capture card). In such case, PCI/VGA is silent while the MPEG /Video capture card is set to function normally. The Choices: Enabled and Disabled

Load Optimized Defaults

Select Defaults from the top menu to access the Load Optimized Defaults settings. When you select this item you get a confirmation dialog box with a message similar to:

Load Optimized Defaults (Y /N)?

Pressing "Y" loads the default values that are factory settings for optimal performance system operations.

Security Setup

You can set the password to restrict unauthorized access to enter or change the options of the setup menus. To abort the process at any time, press Esc.

NOTE:

To clear the password, simply press Enter when asked to enter a password. This disables the password function.

PC Health Setup

Choosing the PC Health option from the top menu provides access to the following functions:

Table 3-23. PC Health Setup Functions

Menu Field	Descriptions
Shutdown Temperature	You can set the shutdown temperature. When the temperature of your system reaches the limitation, the system will shut down automatically to prevent damage caused by overheat. The choices (°C / °F): Disabled, 60/140, 65/149, and 70/158
Power-on show status	Enable this function to show hardware monitor listing after powering on idle system. The choices: Enabled and Disabled
CPU fan low speed warning	Select the speed limits for the CPU fan. When the speed of the CPU fan drops down to the limitation, the system would send out a warning signal. The choices: 2000 RPM, 3000 RPM, 4000 RPM, and Disabled.

Clk/Voltage Setup

Choosing the Clk/Voltage option from the top menu provides access to the CPU Clock Ratio, Auto Detect DIMM/PCI CLK and Spread Spectrum functions. See Table 3-24 for a description of these functions.

Table 3-24. Clk/Voltage Setup Functions

Menu Field	Description
CPU Clock Ratio	The CPU Clock Ratio may be set for your system. If your CPU does not provide for clock ratio modification, this item will be hidden or it will not work. The choices: 8X thru 50X
Auto Detect DIMM/PCI CLK	This item allows you to set the DIMM/PCI clock to enable, disable, or auto detect. The choices: Enabled and Disabled
Spread Spectrum	When the system clock generator pulses, the extreme values of the pulse generate excessive EMI. Enabling pulse spectrum spread modulation changes the extreme pulse spikes to flat curves, thus reducing EMI. This benefit may in some cases be outweighed by problems with timing-critical devices, such as a clock-sensitive SCSI device. The choices: 0.25%, 0.50%, and Disabled

Exit Setup

Choosing Exit from the top menu provides access to two options to exit the program. Table 3-25 describes these options.

Table 3-25. Exit Setup Menu Options

Menu Field	Description
Save & Exit Setup	If you select this option and press <Enter> from the top menu, the values you entered in the setup utilities will be recorded in the chipset's CMOS memory. The microprocessor will check this every time you turn your system on and compare this to what it finds as it checks the system. This record is required for the system to operate.
Exit without saving	Selecting this option and pressing <Enter> lets you exit the Setup program without recording any new values or changing old ones.

Chapter 4 – Maintenance

The 1600 is designed to withstand the harsh environment of the factory floor. Routine maintenance can help keep your 1600 in good operating condition. Preventive maintenance consists of several basic procedures that significantly reduce the chance of system malfunction. Schedule preventive maintenance along with the regular equipment maintenance to minimize down time.

General Preventive Maintenance

Here are some preventive measures you can take:

- *Clean the fan filter periodically* to ensure that the air circulating in the unit is clean. Wash the filter with warm water and dish soap, and let it air dry. Do not scrub the filter, and do not re-install it into the unit until it is completely dry.

Caution

Do not operate the 1600 without a fan filter. Dust build-up could cause the unit to malfunction.

- *Base your maintenance schedule on the operating environment of the system.* If the area is dusty, you should schedule maintenance more often than if it is a dry, clean area. Check the filter often to determine if it needs to be changed ahead of schedule.
- *Remove dust and dirt from PC components.* If dust builds up on heat sinks and circuitry, an obstruction of heat dissipation could cause the unit to malfunction. If dust reaches the electronic boards, a short circuit could occur.
- *Check the connections to I/O modules,* especially in environments where shock could loosen the connections. Check to see that all plugs, sockets, terminal strips, and module connections are secure.
- *Remove unnecessary articles,* such as drawings or manuals, from the unit. They can obstruct airflow and create hot spots, which causes the system to malfunction.
- Do not place noise-generating equipment near the 1600.
- *Stock spare parts* to minimize down time resulting from part failure. The spare parts stocked should be 10-percent of the number of each unit used. The main CPU cards should have one spare each. Each power supply should have a back up. In certain applications where immediate operation of a failed system is required, you may need to stock a spare computer module.
- *Replace the module* with the correct type. If the new module solves the problem but the failure recurs, check for inductive loads that may be generating voltage and current spikes, which may require external suppression.

Fan Filter Replacement

There are two air filters in your 1600 unit, which are located in the front door. To change the fan filters, open the front door of the unit. (See Figure 1-1 to locate the filters.) Remove the 6/32 lock nuts from around the filter covers, and lift the covers off. Replace the filters and then put the filter covers back on. Reattach the 6/32 nuts and close the door.

Fuse Replacement

The 1600 has no accessible fuse. Return the unit to Xycom for fuse replacement.

Recommended Hard Drive Preventive Maintenance

Xycom Automation has recognized that hard drive failures may begin to increase an average of four to five years into the life of most computers used in industrial applications. Therefore, it is our recommendation as a preventive maintenance measure, that all hard drives used in these types of applications be replaced before the four to five year time period to avoid any down time related to hard drive failure.

Xycom believes it is important to keep our customers informed, to offer alternative solutions, and to provide all of our customers with the excellent service they deserve.

Any questions regarding this issue may be directed to our support center at support@xycom.com.

Note

Xycom recommends frequent backups of your hard drive, especially before beginning preventive maintenance procedures.

Product Repair Program

Xycom Automation's Product Repair & Customization Department (PR&C) restores equipment to normal operating condition and implements engineering changes that enhance operating specifications. Xycom Automation tests products returned to Xycom with the standard Xycom test diagnostics.

Follow the steps below to prepare the unit for shipment:

1. Obtain a Return Merchandise Authorization (RMA) number for your unit by calling your nearest Xycom Automation Repair Department or Xycom Automation, Inc. at 734-429-4971 or 1-800-AT-XYCOM.
2. Please have the following information:
 - Company name, shipping and billing address
 - Type of service desired: product repair or product exchange
 - Product model number, part number, quantity, serial number(s), and warranty status
 - Failure mode and failure systems
 - Purchase order number or repair order number
3. Make sure the front panel assembly is properly attached to the unit.
4. Attach failure information to the unit to speed processing.
5. Place the unit securely in its original packaging or an equivalent heavy-duty box.
6. Mark the RMA number on your purchase order and on the outside of the box.
7. Send the unit to the address given when you receive your RMA number.

Chapter 5 – Troubleshooting

Troubleshooting Tables

Included in this section are two troubleshooting tables to help diagnose and correct problems.

Table 5-1 offers actions for problems that occur without an error message. Table 5-2 offers actions for error messages that occur during the POST.

Each chart provides one or more probable causes and a corresponding course of action. The tables are only guidelines and do not replace proper diagnostic procedures. Xycom recommends you verify that the actions taken to correct a problem are appropriate.

Xycom also recommends that you attempt to determine the failure's root cause. For example, if the line fuse has blown, establishing the reason for the excess current that caused the fuse to blow will help to prevent it from happening again.

General Operational Problems

Use Table 5–1 when there is a problem, but no error messages occur during power-up or normal operation.

Table 5-1. Troubleshooting General Problem

Problem	Possible Cause	Action
Blank screen on attached monitor	Power disconnected	Check power supply voltage and connection integrity.
	Video cable disconnected	Check video cable and connection integrity.
	Line fuse blown	Determine cause and replace fuse.
	Faulty RAM	Replace DIMMs.
Screen color or picture is distorted	Video drivers were not loaded	Load correct video drivers from the Documentation and Support Library CD-ROM that was shipped with the unit.
Printer functions not working	Printer is not on-line	Check printer power and on-line status.
	Cable disconnected	Check cable connections.
	Improper HMI or other application print function parameters	Check print function settings for correct printer type, page size, and orientation. Refer to the applicable software documentation.
	CMOS setup is incorrect	Verify CMOS setup and correct if necessary.
	Printer port configuration incorrect	Check printer port configuration
	HMI or other application software configuration problem	Check software configuration. Refer to the applicable software documentation.
	Printer not working	Replace printer
Floppy disk drive not working	Disk not formatted	Use formatted disk
	CMOS configuration incorrect	Check CMOS setup data for floppy enable.
	Floppy disk cables not connected correctly	Check power and data cable connections.
	Floppy disk drive configuration incorrect	Check that drive is installed, configured, and connected.
Hard disk drive not working	CMOS configuration incorrect	Check CMOS setup data
	Disk not formatted or partitioned	Format and install software.
	Disk drive cables not connected correctly	Check power and data cable connections.
	Disk drive configuration incorrect	Check drive configuration.
	Operating system not loaded	Load operating system.

BIOS Error Messages

Use Table 5-2 when the BIOS detects a problem during the Power-On Self-Test (POST). After the problem is detected, a BIOS error message will display (before the Windows operating system starts).

Table 5-2. Troubleshooting BIOS Error Messages

Message	Possible Cause	Action
Keyboard error	A key was held during Power-On Self-Test (POST)	Reboot with no keys pressed.
	Keyboard malfunction	Replace keyboard.
Real-time clock error	Real-time clock information lost	Reset time and date in Setup Menu, and reboot.
	Hardware error in real-time clock	Replace CPU board.
Operating system not found	A non-system floppy disk is present in the floppy disk drive	Remove disk and reboot.
	CMOS setup data is incorrect	Verify CMOS setup data, correct if necessary, and reboot.
	Hard disk has lost operating system data	Partition and reformat hard disk. If problem persists, the hard disk may need to be replaced.
	Hard disk has failed	Replace hard disk.
Failure fixed disk	Hard disk cabled disconnected	Check hard disk cables for proper connection. Verify hard disk spins up when power is applied.
	CMOS setup data is incorrect	Verify CMOS setup data, correct if necessary, and reboot.
	Hard disk has lost operating system data	Partition and reformat hard disk. If problem persists, the hard disk may need to be replaced.
	Hard disk has failed	Replace hard disk.
Incorrect Drive A type. Run SETUP	CMOS setup data is incorrect	Verify CMOS setup data, correct if necessary, and reboot.
Floppy disk controller error or no controller present. Press F2 on keyboard for setup.	Floppy disk drive configuration incorrect	Check floppy disk cables and disk controller configuration. Replace floppy disk drive if malfunction persists.
System CMOS checksum bad. Run SETUP.	CMOS data corrupted	Input correct CMOS setup data, save values, and reboot.
(# of kbytes) K System RAM failed at offset	Diagnostic message	Visually inspect memory modules for poor connection. Replace CPU board if problem persists.
(# of kbytes) K System RAM passed	POST memory test passed	No action required.
System BIOS shadowed	BIOS areas being shadowed	No action required.
Video BIOS shadowed	BIOS areas being shadowed	No action required.
Previous boot incomplete. Default configuration used.	Previous boot did not complete	Enter setup, access the Exit Menu, choose the "Get Default Values" option, save the settings, exit Setup, and then reboot.
Diskette drive A (or B) error	Floppy drive error	Check cable to floppy drive and check the Setup Menu configuration, and then reboot.

Diagnostic Testing

On units with MS-DOS installed, diagnostic testing is provided as a tool to verify the operation of the system hardware functions. If any of these tests fail, either the default setting is incorrect, or there is a general failure. Check the default settings and run the tests again. If another failure occurs, contact Xycom's Product Repair & Customization Department (see *Product Repair Program* for more information).

Caution

Remove any device drivers or memory resident programs (TSRs) installed on the system before running Xycom diagnostic tests. If you do not, unexpected failures may occur.

Note

You must hook up a monitor before running any tests.

Preparing for the Tests

To test your system, you need the following equipment:

- Floppy disk drive
- IBM PC or PS/2-compatible keyboard
- Diagnostic Disk shipped with your computer
- Supplemental Software Floppy Disk
- Centronics-compatible printer cable
- Parallel printer (Centronics-style interface)
- Two serial loopback test connectors (refer to Figure 5-1 for pinouts)
- Formatted 3.5-inch, DS/HD (1.44 MB) disk

Set BIOS to Defaults

Make sure the BIOS setup menu is configured to the factory-set defaults.

To enter the Setup Menu:

1. Press POWER on the 1600 unit and immediately press .
2. Make the necessary changes by following directions on the screen.
3. Press ESC.
4. Press ENTER twice to save the Setup and exit.

Prepare the System

Before starting the system tests, perform the following steps:

1. Set the CPU board jumpers and switches to the factory set positions. Refer to your CPU manual for these settings.
2. Plug the female end of the AC power cable into the rear of the unit and the male end into a properly grounded outlet.
3. Connect the serial loopback connector(s) and the printer cable to the appropriate connectors and connect a PC/AT or PS/2 keyboard. Figure 5–1 illustrates the wiring necessary for the loopback connection.
4. Default the CMOS setup to the factory settings.

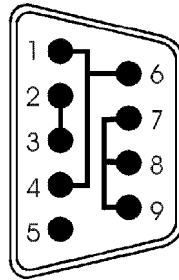

Com 1 Serial Loopback
Connections

Figure 5-1. Serial Loopback Connection

Running the Tests

To run the test, insert the diagnostics disk into drive A. Turn on the computer and the diagnostics program will boot-up. The following figure shows the Main Menu.

Copyright 1990-1996, Xycom, Inc. All rights reserved. Diagnostic Tests Sequence/Selection Menu (Rel. xx)	
1. WILL pause on error 2. SINGLE PASS test mode 3. Save setup to file 4. Extract setup from a file 5. Auto-select tests 6. Deselect all tests 7. Quit and exit to DOS 8. Return to previous screen	
A) RAM Test B) Video RAM Test C) Extended RAM Test D) Real Time Clock Test E) COM1 Serial Port Test F) COM2 Serial Port Test G) COM3 Serial Port Test H) COM4 Serial Port Test I) Math Coprocessor Test J) Video Adjustments Test	K) Video Interface Test L) Speaker Port Test M) LPT1: Printer Port Test N) LPT2: Printer Port Test O) C: Hard Drive Interface Test P) D: Hard Drive Interface Test Q) A: Floppy Drive Interface Test R) B: Floppy Drive Interface Test S) Keyboard, Keypad Tests = = Test Selected
[ENTER]=START TESTING Use the letters to move the cursor and select/deselect, or use the arrow keys to move, then use the [SPACE] key to select/deselect a test or function.	

Figure 5-2. Main Menu

Note

Please read the DIAG.TXT file on the diagnostics disk for detailed information about the tests.

Caution

Avoid repeated running of any hard disk diagnostic utility if you use the Solid State (Flash) drive option. The Flash drive has a limited number of writes to each logical sector. Repeated writes from a diagnostic utility will prematurely shorten the life of the drive.

Reinstalling Operating Systems

The 1600 series CPU ships with MS-DOS preinstalled. Windows 98, Windows 2000, Windows NT, and Windows XP Professional operating systems are also available. If you need to reinstall an operating system, refer to the appropriate section below. If you want to change operating systems, you will need to use the manufacturer's instruction manual.

Note

If you need to reinstall the Windows 98, Windows 2000, Windows NT, or Windows XP Professional operating system, you must have an internal CD-ROM drive or an external parallel port CD-ROM drive.

MS-DOS® Reinstallation

If you need to reinstall MS-DOS, refer to the *Xycom Automation Workstation Recovery Media Software Installation Instructions for Microsoft DOS 6.22* (shipped with systems preinstalled with MS-DOS). This document is devoted to the reinstallation of your MS-DOS operating system and drivers, utilizing the Recovery Media provided with your Xycom Automation industrial computer.

Note

This procedure assumes that the computer hard disk drive has been completely corrupted or replaced.

Warning

This procedure will destroy data that may exist on the hard disk drive.

Note

MS-DOS does not support audio; there are no audio drivers available for MS-DOS.

Windows® 98 Reinstallation

If you need to reinstall the Windows 98 operating system, refer to the *Xycom Automation Workstation Recovery Media Software Installation Instructions for Microsoft Windows 98* (shipped with systems preinstalled with Windows 98). This document is devoted to the reinstallation of your Microsoft Windows 98 operating system and drivers, utilizing the Recovery Media provided with your Xycom Automation industrial computer.

Note

This procedure assumes that the computer hard disk drive has been completely corrupted or replaced.

Warning

This procedure will destroy data that may exist on the hard disk drive.

Windows® 2000 Reinstallation

If you need to reinstall the Windows 2000 operating system, refer to the *Xycom Recovery for Xycom Automation Windows 2000 Workstation* (shipped with systems preinstalled with Windows 2000). This document is devoted to the reinstallation of your Windows 2000 operating system and drivers, utilizing the Recovery Media provided with your Xycom Automation industrial computer. If you want to install a new operating system or reinstall a current operating system, refer to the operating system's manual for directions.

Note

This procedure assumes that the computer hard disk drive has been completely corrupted or replaced.

Warning

This procedure will destroy data that may exist on the hard disk drive.

Windows NT® Reinstallation

If you need to reinstall the Windows NT operating system, refer to the *Xycom Recovery for Xycom Automation Windows NT Workstation* (shipped with systems preinstalled with Windows NT). This document is devoted to the reinstallation of your Windows NT Workstation 4.0 operating system and drivers, utilizing the Recovery Media provided with your Xycom Automation industrial computer.

Note

This procedure assumes that the computer hard disk drive has been completely corrupted or replaced.

Warning

This procedure will destroy data that may exist on the hard disk drive.

Windows XP® Reinstallation

If you need to reinstall the Windows XP Professional operating system, refer to the *Windows XP Professional* CD-ROM (shipped with systems preinstalled with Windows XP Professional).

Note

This procedure assumes that the computer hard disk drive has been completely corrupted or replaced.

Warning

This procedure will destroy data that may exist on the hard disk drive.

Installing Drivers

This section describes how to install the drivers associated with the 1600. Information about installing drivers for your computer is included in the *Documentation and Support Library CD* shipped with your computer, or on the web at www.xycom.com.

Note

For further assistance, call Xycom Automation technical support at 734-429-4971 ext. 595 or 1-800-AT-XYCOM.

Note

MS-DOS does not support audio; there are no audio drivers available for MS-DOS.

Ethernet Drivers

If MS-DOS® is installed on your system, the Ethernet drivers are supplied on your hard drive in the C:\netdrv directory, but they are not installed.

To install the MS-DOS Ethernet drivers,

1. At the C: prompt, type “cd netdrv”.
2. Once the C:\netdrv path is specified, type “install”.
3. Follow the on-screen instructions to complete installation.

If you install Windows® on your system, Xycom provides the appropriate Ethernet drivers. They can be found on the Ethernet Drivers disk that ships with your system, on the *Documentation and Support Library CD*, or on the web at www.xycom.com.

Note

If you install Windows® NT 4.0, be aware that the Ethernet driver included in that operating system may not work with the Ethernet controller in the 1600. You must use the drivers provided by Xycom.

These drivers can be found on the Ethernet Drivers disk or Documentation Support Library CD that ships with your system, or on the web at www.xycom.com.

Video Drivers

Video drivers for each operating system are on the diskettes included with the documentation kit. Drivers are also included on the *Documentation and Support Library CD* or on the web at www.xycom.com. To install a video driver, refer to the INSTALL.TXT file on the diskette for your operating system.

CD-ROM Drivers

A CD-ROM driver disk comes with the CD-ROM option, as well as the preinstalled driver for the operating system you have selected. Drivers are also included on the *Documentation and Support Library CD* or on the web at www.xycom.com. If you change operating systems and need help loading the required CD-ROM driver, contact Xycom technical support at 1-800-AT-XYCOM ext. 595.

Miscellaneous Drivers

Refer to your operating system and peripheral manuals for information on installing drivers related to these items.

Note

For further assistance, call Xycom Automation Technical Support at 734-429-4971 ext. 595 or 1-800-AT-XYCOM

Appendix A – Technical Specifications

Hardware Specifications

Table A - 1 lists the hardware specifications for the 1612, 1613, and 1614 CPU.

Table A - 1. 1600 Hardware Specifications

Characteristic	Specification			
Mechanical*	1612	1613	1614	
	Height	7.00" (177.8mm)	7.00" (177.8mm)	7.00" (177.8mm)
	Width	19.00" (482.6mm)	19.00" (482.6mm)	19.00" (482.6mm)
	Depth	17.88" (454.0mm)	19.88" (504.8mm)	22.88" (581.0mm)
Power Supply	300 W AC or 2x 300 W AC redundant			
Input Rating	115-230 V AC, auto-ranging, 50-60 Hz, 7 A maximum @ 115V, 3 A maximum @ 230V			
Passive Backplane	Ten available expansion slots:			
	1612	1613	1614	
	Three full-length ISA	Three full-length ISA	Three full-length ISA	
	One full-length PCI	One full-length PCI	Four full-length PCI	
	Two ¾ length PCI	Six ¾ length PCI	Three ¾ length PCI	
	Four ½ length PCI			
Agency Approvals	UL 508 (Listed) Industrial Control Equipment cUL CSA-C22.2, No. 142 Process Control Equipment			
Regulatory Compliance	FCC 47 CFR, Part 15, Class A CE: EMI EN55022, Class A IMMUNITY EN61000-6-2 HARMONICS EN61000-3-2, Class A FLICKER EN61000-3-3 SAFETY EN60950, CB Report			
ISO 9001	The manufacturing facility at Xycom, Inc. is ISO certified and is accredited by ANSI-RAB and the RvA.			

* See pages 11-13 for detailed dimensions.

Environmental Specifications

Table A - 2 lists the environmental specifications for the 1600 series Industrial PC.

Table A - 2. 1600 Environmental Specifications

Characteristic	Specification
Temperature	
Operating	0° to 50° C (32° to 122° F)
Nonoperating	-20° to 60° C (-4° to 158° F)
Humidity	
Operating	20% to 80% RH non-condensing
Non-operating	5% to 90% RH non-condensing
Altitude*	
Operating	Sea level to 15,000 feet
Non-operating	Sea level to 50,000 feet
Vibration**	
Operating	5-2000 Hz, 0.006" peak-to-peak displacement .5g maximum acceleration
Non-operating (packaged)	5-2000 Hz, 0.081" peak-to-peak displacement 2.g maximum acceleration
Shock**	
Operating	2g peak acceleration, 11 msec duration, ½ sine wave
Non-operating (packaged)	7.5g peak acceleration, 11 msec duration, ½ sine wave

*These values are consistent with internal component specifications.

**These values are with solid state hard drives and not rotating media drives.

Note

CD-ROM and standard hard disk drives should not be used in applications where high levels of shock and vibration are present.

If a CD-ROM drive is installed, the shock and vibration specifications of the 1600 are limited to the shock and vibration specifications of the CD-ROM drive.

Appendix B – Programming the SBC-860 Watchdog Timer

SBC-860 utilizes the ITE 8712 chipset as its watchdog timer controller. Follow the procedures below to complete its configuration.

1. Enter the MB PnP mode
2. Select logical device
3. Configure the watchdog timer controller registers
4. Exit the MB PnP mode

To enter the MB PnP mode, write the value 87h, 1h, 55h, 55h to configuration port -2Eh. To exit the MB PnP mode, set bit 1 of the control register (index 02h) to 1. The initial watchdog timer program is illustrated below. This program applies only to DOS and Windows® 9X.

Refer to the following example for more information

```
=====
Enter the MB PnP mode
=====
mov  al, 87h
out  2eh,al
mov  al,l
out  2eh, al
mov  al, 55h
out  2eh, al
out  2eh, al
=====
Select logical device
=====
mov  al, 7          ; index 7 for logical device
out  2eh, al
mov  al, 7
out  2fh, al
```

```
=====
Configure watchdog timer registers
=====
```

```
mov  al, 73h
out  2eh, al
mov  al, 0ah      ; 0000 1010
out  2fh, al      ; index 73h for watchdog time-out value
mov  al, 72h
out  2eh, al
mov  al, 0c0h     ; 1100 0000
out  2fh, al      ; time-out value – use second & enable WDT output
                        ; through KRST
```

```
=====
Exit the MB PnP mode
=====
```

```
mov  al, 2h
out  2eh, al
out  2fh, al
```

Additional information, copied from the ITE 8712 manual is on the next page.
The complete manual for the ITE 8712 Super I/O chip can be found at
http://www.ite.com.tw/pc/IT8712_V07.pdf

The Watch Dog Timer (WDT) function is constituted by a time counter, a time-out status register, and the timer reset control logic. The time-out status bit may be mapped to an interrupt or KRST# through the WDT Configuration register. The WDT has a programmable time-out range from 1 to 255 minutes or 1 to 255 seconds. The units is also programmable, either a minute or a second, via bit7 of the WDT Configuration register. When the WDT Time-out Value register is set to a non-zero value, the WDT loads the value and begin counting down from the value. When the value reaches to 0, the WDT status register will be set. There are many system events that can reload the non-zero value into the WDT, which include a CIR interrupt, a Keyboard Interrupt, a Mouse Interrupt, or I/O reads/writes to the Game Port base address. The effect on the WDT for each of the events may be enabled or disabled through bits in the WDT control register. No matter what value in the time counter is, the host may force a time-out to occur by writing a "1" to the bit 1 of the WDT Configuration register.

8.11.8 Watch Dog Timer Control Register (Index=71h, Default=00h)

Bit	Description
7	WDT is reset upon a CIR interrupt
6	WDT is reset upon a KBC (mouse) interrupt
5	WDT is reset upon a KBC (keyboard) interrupt
4	WDT is reset upon a read or a write to the Game Port base address
3-2	Reserved
1	Force Time-out This bit is self-clearing
0	WDT Status 1: WDT value reaches 0. 0: WDT value is not 0.

8.11.9 Watch Dog Timer Configuration Register (Index=72h, Default=00h)

Bit	Description
7	WDT Time-out value select 1 1: Second 0: Minute
6	WDT output through KRST (pulse) enable 1: Enable. 0: disable
5	WDT Time-out value Extra select 1: 64 ms. 0: Determine by WDT Time-out value select 1 (bit 7 of this register).
4	WDT output through PWROK1/PWROK2 (pulse) enable 1: Enable. 0: disable
3-0	Select the interrupt level ^{Note1} for WDT

8.11.10 Watch Dog Timer Time-Out Value Register (Index=73h, Default=00h)

Bit	Description
7-0	WDT time-out value 7-0

Note 1:

Interrupt level mapping
Fh-Dh: not valid
Ch: IRQ12

3h: IRQ3
2h: not valid
1h: IRQ1
0h: no interrupt selected

Appendix C – The RAID-Enabled IPC Option

The component most susceptible to shock and vibration in any Industrial PC is the hard drive. Some sources suggest shock mounting the hard drive; unfortunately, shock mounting may cause the hard drive to become more vibration-sensitive at certain frequencies. The most common methods to overcome a susceptibility to vibration are through the use of either solid-state storage media or redundant hard drives. Many of Xycom Automation's Heavy-Duty Industrial PCs offer solid-state media in the form of CompactFlash™ or solid-state hard drives. While many storage sizes are available, the cost of solid-state drives escalates considerably as the required drive size increases.

A second approach is to use RAID. (RAID stands for Redundant Array of Independent Disks.) In essence, RAID is two or more hard drives hooked up to the same controller, either SCSI or IDE. The RAID controller can "stripe" or "mirror" data. Striping (RAID 0) is used to read and write to many disks at once to increase hard drive performance, while mirroring (RAID 1) allows the same data to be available on two or more drives.

There are two methods to implement a RAID solution – via software or dedicated hardware. Xycom has chosen a hardware solution because software solutions are more limited, and require a Windows® 2000 or 2003 Server.

Xycom's hardware RAID solution utilizes the Adaptec ATA RAID 1200A, a PCI IDE¹ RAID controller card. This controller card is installed in the PC, and the array drives are connected to it, instead of to an IDE controller. Most PCs use an IDE controller to interface between the system and the hard disks. The RAID controller occupies a single PCI slot, so you need to verify the available expansion in your Industrial PC for the application. RAID 1 with two hard drives was chosen as the optimal solution for creating a more robust, fault-tolerant system in the Xycom 1507, 3700 Series, and 1600 Series of Heavy-Duty Industrial PCs. Xycom has chosen to support Windows® 2000 and Windows® XP for these RAID-enabled assemblies for optimal and reliable performance.

Note

When installed, the RAID controller bypasses the disk controller on the AIM3 board that runs the disk activity light. Therefore, the disk activity light on the 3700 Series units will not function for the HDDs once the RAID controller is installed. However, the disk activity light will function for the CD-ROM, CompactFlash or any X-Bay units, as the RAID controller does not bypass these items.

In a RAID 1 system, there is a primary and a secondary hard drive. The RAID controller writes to both drives, but only reads from the primary drive. If the RAID

¹ ATA and IDE are used interchangeably in this context. IDE stands for Integrated Drive Electronics; ATA stands for Advanced Technology Attachment. Both terms refer to the type of controller used in PCs.

controller detects any problems with the primary drive, it switches over to the secondary drive (which has an exact copy of all data on the primary drive) and informs the operator of the switchover. If the RAID controller should detect any problems with the secondary drive, it stops writing to it and informs the operator of the problem. In either case, the operator can schedule a time to replace the failed drive.

Note

The RAID-Enabled Industrial PC is configured at time of manufacture. The RAID controller is not available as a user-installable upgrade.

When you order a RAID-enabled Industrial PC, the Adaptec controller will be installed and configured in the unit at the Xycom plant. And, in addition to the items listed in Chapter 2, you will receive the Adaptec ATA RAID 1200A Installation and User's Guide, and the Adaptec RAID driver disk. These items will help you to understand and use your RAID-Enabled PC. The Installation and User's Guide covers:

- Installation of the Adaptec controller
- Using the BIOS array Configuration Utility
- Installation of the device driver
- Using the ATA RAID management software.

There is also a troubleshooting section to assist you with any questions that may arise. You may also contact Xycom Automation Technical Support at support@xycom.com or (734) 944-0482 for assistance

INDEX

approvals	17	LPT1 port	26
BIOS setup menus	57	maintenance	51
CD-ROM drivers	63	Maintenance	
COM1 port	26	hard drive	52
COM2 port	26	mounting	9, 14
connectors		Operating systems	
parallel port (LPT1)	26	installation	60
serial port	26	parallel port (LPT1)	26
diagnostic testing	57	pinouts	
documentation kit	7	parallel port (LPT1)	26
DRAM installation	18	serial ports	26
drivers		VGA connector	29
CD-ROM	63	ports	
installation	62	COM1	26
miscellaneous	63	COM2	26
video	63	parallel (LPT1)	26
electrical noise	17	VGA	29
environmental specifications	65	power	16
<i>Fan</i>	51	Preventive maintenance	
filter replacement	52	hard drive	52
fan and filter	4	product overview	1
features		product repair service	52
standard	1	safety agency approval	17
fuse, replacing	52	serial ports	26
hardware specifications	64	<i>Spare parts</i>	51
heat, excessive	16	standard features	1
installation		start-up	8
DRAM	18	system power	16
drivers	62	testing, diagnostic	57
Installation		unpacking the system	7
operating systems	60	VGA connector	29
LEDs	4	video drivers	63
line voltage variation	17		

143158(C)

Xycom Automation, Inc.
734-429-4971
Fax: 734-429-1010
<http://www.xycom.com>

Canada Sales: 905-607-3400
Northern Europe Sales: +44-1604-790-767
Southern Europe Sales: +39-011-770-53-11

