

4115T

15" Light Duty Industrial PC

Revision	Description	Date
A	Manual Released	7/05

Part Number 143926 (A)

Trademark Information

Brand or product names are registered trademarks of their respective owners. Windows is a registered trademark of Microsoft Corp. in the United States and other countries.

Copyright Information

This document is copyrighted by Xycom Automation Incorporated (Xycom Automation) and shall not be reproduced or copied without expressed written authorization from Xycom Automation.

The information contained within this document is subject to change without notice. Xycom Automation does not guarantee the accuracy of the information.

United States FCC Part 15, Subpart B, Class A EMI Compliance Statement:

NOTE: This equipment has been tested and found to comply with the limits for a Class A digital device, pursuant to part 15 of the FCC Rules. These limits are designed to provide reasonable protection against harmful interference when the equipment is operated in a commercial environment. This equipment generates, uses, and can radiate radio frequency energy and, if not installed and used in accordance with the instruction manual, may cause harmful interference to radio communications. Operation of this equipment in a residential area is likely to cause harmful interference in which case the user will be required to correct the interference at his or her own expense.

For European Users - WARNING:

This is a Class A product. In a domestic environment this product may cause radio interference in which case the user may be required to take adequate measures.

INSTALLATION: Electromagnetic Compatibility WARNING:

The connection of non-shielded equipment interface cables to this equipment will invalidate FCC EMI and European Union EMC compliance and may result in electromagnetic interference and/or susceptibility levels which are in violation of regulations applying to the legal operation of this device. It is the responsibility of the system integrator and/or user to apply the following directions relating to installation and configuration:

All interface cables must include shielded cables. Braid/foil type shields are recommended. Communication cable connectors must be metal, ideally zinc die-cast backshell types, and provide 360-degree protection about the interface wires. The cable shield braid must be terminated directly to the metal connector shell, ground drain wires alone are not adequate.

Protective measures for power and interface cables as described within this manual must be applied. Do not leave cables connected to unused interfaces or disconnected at one end. Changes or modifications to this device not expressly approved by the manufacturer could void the user's authority to operate the equipment.

EMC compliance is, in part, a function of PCB design. Third party add-on AT/XT peripheral PCB assemblies installed within this apparatus may void EMC compliance. FCC/CE compliant PCB assemblies should always be used where possible. XYCOM AUTOMATION can accept no responsibility for the EMC performance of this apparatus after system integrator/user installation of PCB assemblies not manufactured and/or expressly tested and approved for compliance by XYCOM AUTOMATION. It is the responsibility of the system integrator/user to ensure that installation and operation of such devices does not void EMC compliance.

Table of Contents

CHAPTER 1 – INTRODUCTION	1
GENERAL INFORMATION.....	1
<i>Standard Features</i>	1
<i>LCD Display</i>	1
<i>Touch Screen</i>	2
I/O PANEL.....	2
BACK PANEL	3
FRONT AND SIDE PANELS	4
UNPACKING THE SYSTEM.....	5
QUICK STARTUP	5
CHAPTER 2 — INSTALLATION	6
INSTALLATION OVERVIEW.....	6
MECHANICAL DIMENSIONS	8
MOUNTING OPTIONS	9
<i>Panel Mounting</i>	9
<i>Wall Mounting</i>	11
<i>Arm Mounting</i>	13
CHAPTER 3 – POS-478 CPU BOARD AND AMI BIOS SETUP	14
POS-478E CPU BOARD	14
<i>Product Overview</i>	14
<i>Specifications</i>	14
POS-478E CPU BOARD LAYOUT	15
<i>Jumper Settings</i>	16
<i>Connector Pin Outs</i>	21
AMI BIOS SETUP.....	31
<i>Starting Setup</i>	31
<i>Using Setup</i>	32
<i>Getting Help</i>	32
<i>Main Menu</i>	33
STANDARD CMOS SETUP	34
<i>Advanced CMOS Setup</i>	36
ADVANCED CHIPSET SETUP	39
POWER MANAGEMENT SETUP	41
PCI / PLUG AND PLAY SETUP.....	42
PERIPHERAL SETUP	43
<i>Hardware Monitor Setup</i>	44
CHAPTER 4 – MAINTENANCE.....	46
GENERAL PREVENTIVE MAINTENANCE	46
<i>Fuse Replacement</i>	46
RECOMMENDED HARD DRIVE PREVENTIVE MAINTENANCE	46
PRODUCT REPAIR PROGRAM / RETURNING A UNIT TO XYCOM AUTOMATION	47
CHAPTER 5 – TROUBLESHOOTING.....	48
DIAGNOSTIC TESTING.....	48
RUNNING THE TESTS.....	50
REINSTALLING OPERATING SYSTEMS	51
<i>Windows® 2000 Reinstallation</i>	51
<i>Windows XP® Reinstallation</i>	51
INSTALLING DRIVERS.....	52
<i>Video Drivers</i>	52
<i>Touch Screen Drivers</i>	52
<i>Miscellaneous Drivers</i>	53

APPENDIX A TECHNICAL SPECIFICATIONS	54
HARDWARE SPECIFICATIONS.....	54
ENVIRONMENTAL SPECIFICATIONS.....	55
APPENDIX B – WATCHDOG TIMER	56
APPENDIX C – POWER-ON SELF-TEST MESSAGES	58
POST MESSAGES.....	58
POST BEEP.....	58
ERROR MESSAGES.....	58
APPENDIX D – DMA, IRQ AND 1ST MB MEMORY	61
DMA CHANNEL ASSIGNMENTS.....	61
IRQ MAPPING CHART.....	61
1 ST MB MEMORY ADDRESS MAP.....	62
I/O ADDRESSES.....	62
APPENDIX E – HOW TO USE THE WAKE-UP FUNCTION	63
WAKE-UP ON MODEM (RING).....	63
WAKE-UP ON LAN.....	63
APPENDIX F – HOW TO UPGRADE A NEW BIOS	64
BIOS UPDATE PROCEDURE.....	64
RECOVERING YOUR OLD BIOS.....	65

Chapter 1 – Introduction

General Information

The 4115T 15" LCD TFT Panel PC, takes advantage of a modern flat-panel display, POS-478E CPU board, drive spaces and a power supply for minimum size. It is an IBM PC/AT® compatible computer specially designed to meet the applications for industrial environments.

Standard Features

The 4115T comes standard with the following features:

- POS-478E CPU board equipped with a high performance socket Pentium® 4 2.0GHz CPU with 533 MHz front system bus and 512 KB cache
- 10/100Mbps Ethernet
- LCD/CRT interface
- 15" flat panel TFT XGA (1024 x 768) LCD
- 100-240 VAC, 50-60 Hz power supply
- Analog resistive touch screen
- Internal 40GB hard disk drive
- 1.44 MB floppy disk drive
- Slim line CD-ROM drive
- DDR 266, 256MB SDRAM DIMM
- Windows 2000 Operating System

Optional Features:

- DDR 266 512MB -1G SDRAM DIMM
- CD-R/W
- DVD-ROM
- DVD +/-RW with CD-R/W
- Windows XP

LCD Display

Table 1-1 identifies the features of the 4115T LCD display.

Table 1-1. 4115T LCD Display Specifications

Display Model	NEC
Display Type	15" TFT color
Resolution	1024x768
Maximum colors	24 bits
Brightness	250 cd/m ²
Backlight MTBF	50,000 hrs

Touch Screen

Table 1-2 identifies important specifications of the 4115T touch screen.

Table 1-2. 4115T Touch Screen Specifications

Touch Screen Model	Description
Screen Type	Eight wire analog resistive touch screen
Resolution	Continuous
Light Transmission	Typical value 75%
Surface Hardness	4H (Test condition: ASTM D3363-92A)
Support Driver	Supports Windows 2000/XP

The figures on the next several pages show the internal and external components on the front and back panels of the unit to help you locate features relevant to installation.

I/O Panel

The figure below shows the I/O panel of the 4115T.

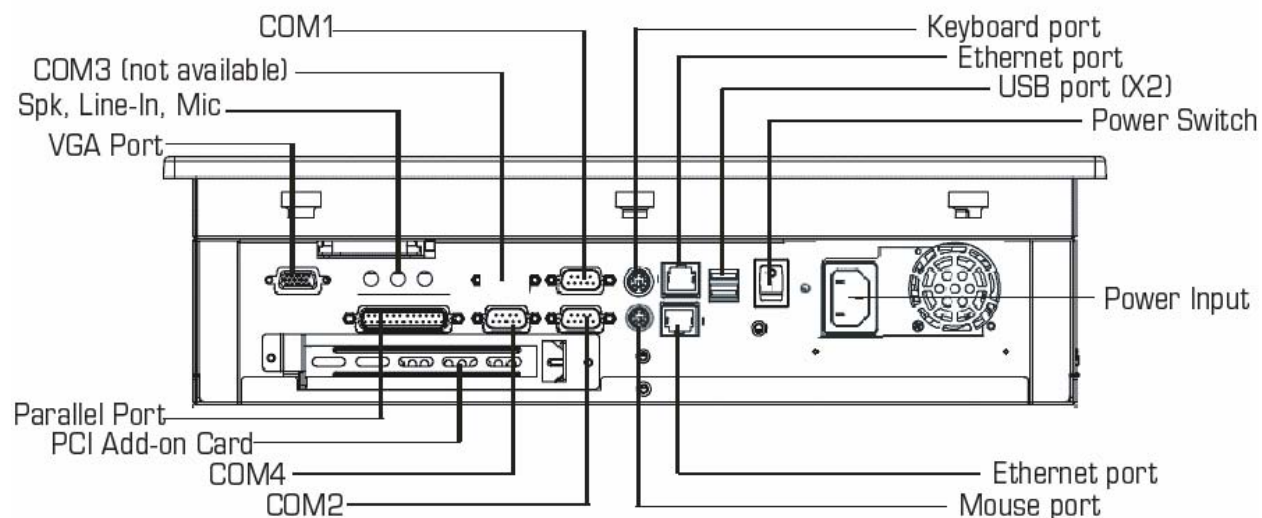

Figure 1-1. I/O Panel

Note: There is only one Ethernet port available

Back Panel

The diagram below shows the back panel of the 4115T. For maintenance, installation or upgrade, first remove the back cover by unfastening seven screws as shown in the diagram below.

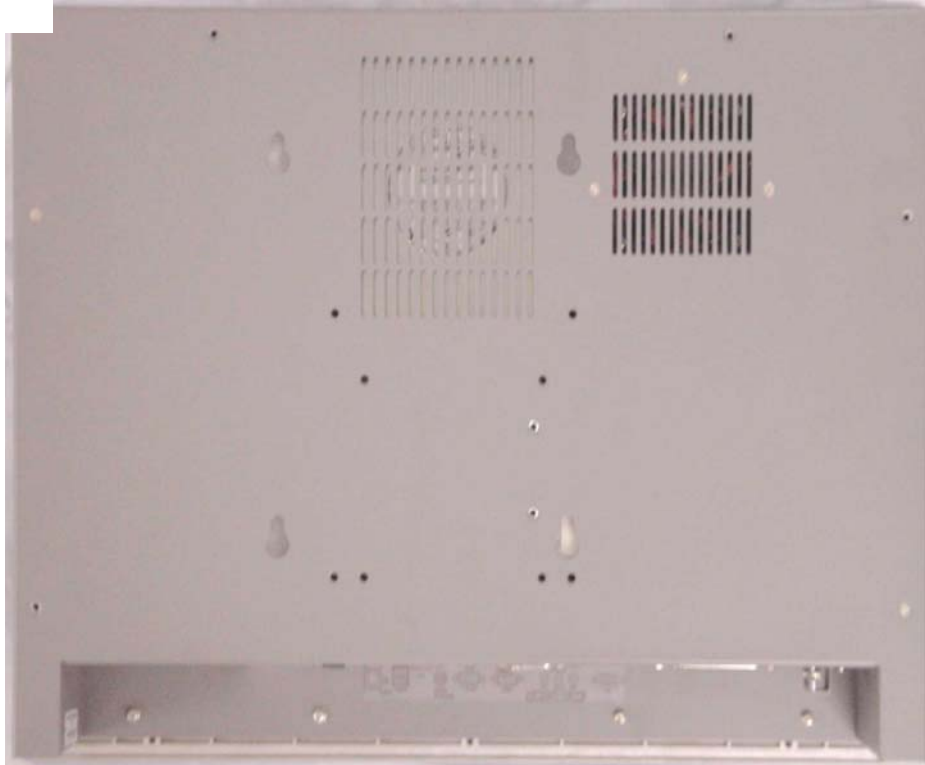

Figure 1-2. System Back Panel

Caution

Before any installation or un-installation, please take precautions to prevent damage to the components due to static electricity.

Front and Side Panels

One Floppy Disk Drive and CD-ROM are accessible from the side of the chassis.

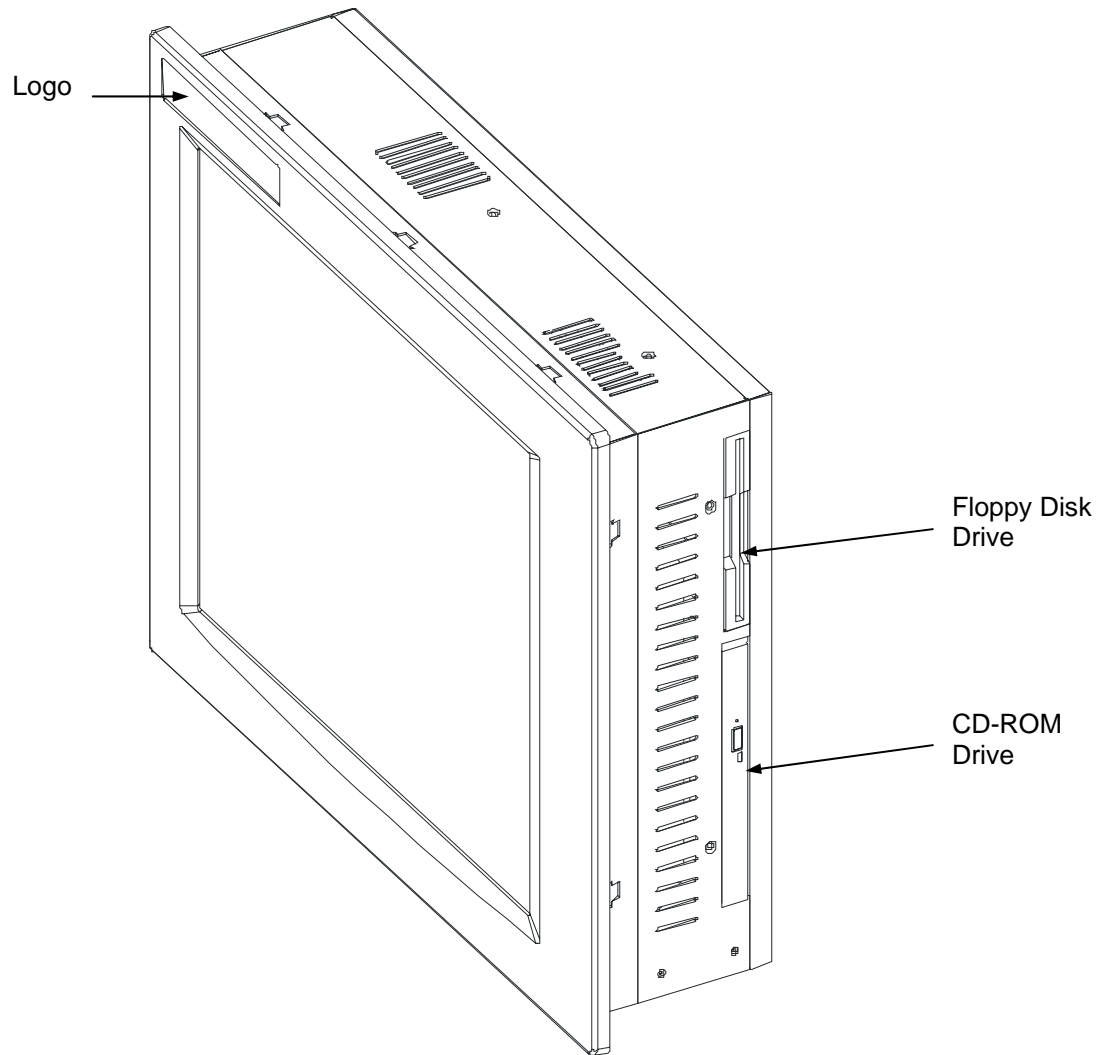

Figure 1-3. Front and Side Panel Views

Unpacking the System

When you remove the system from its shipping container, verify that you have the parts listed below. Save the box and inner wrapping in the event you need to reship the unit.

- 4115T Unit
- Documentation kit, which includes:
 - Power cable
 - Twelve 10-32 hex nuts
 - Documentation and Support Library CD-ROM
 - Operating System Recovery Media or retail operating system (CD-ROM)

Quick Startup

This section gives you the steps to get the system up and running without explaining the capabilities and options.

Warning

Remove power from the unit and disconnect the power cord before making any adjustments to the inside or outside of the computer.

To prepare the system for use, perform the following steps.

1. Attach optional keyboard to the keyboard port, and optional mouse to the mouse port.
2. Confirm that the 100-240 VAC selector switch on the power supply is set appropriately.
3. Attach the power cord from the power receptacle to a properly grounded 100-240 VAC, 50-60 Hz outlet.
4. Turn on power to the unit (via an outlet power switch if applicable). The system will boot up into the operating system.
5. Install application software via the floppy, the CD-ROM, or the network.

Chapter 2 — Installation

Installation Overview

The rugged design of the 4115T unit allows it to be installed in most industrial environments. The system is generally placed in a NEMA 4/4X/12 enclosure to protect against contaminants such as dust, and moisture. Metal enclosures also help minimize the effects of electromagnetic radiation that nearby equipment can generate.

Read the following sections carefully to be sure that you are complying with all the safety requirements.

1. Select a NEMA rated enclosure and place the unit to allow easy access to the system ports (see other sections in this chapter and Appendix A).
 - To assure a NEMA 4 seal choose an approved enclosure that has a 14-gauge (0.075 in/1.9 mm thick steel or 0.125 in/3.2 mm thick aluminum) front face.
 - Be sure to account for the unit's depth when choosing the depth of the enclosure.
2. Create a cutout in the enclosure (see *Figure 2-2*).
 - Be sure to place the unit at a comfortable working level
 - Make sure the area around the cutout is clean and free from metal burrs
3. Mount the unit in an upright position and properly secure the unit into the panel.
 - Tighten the ten #10 nuts to 25 inch-pounds (2.8 Newton-meters / 28Kgf cm).
4. Attach one end of the power cord to the power receptacle on the unit and the other end to a properly grounded 100-240 VAC, 50-60 Hz outlet.
5. Turn on power to the system. The system will boot up the installed operating system.
6. Install the application software via a floppy drive, CD-ROM, or the network.

Additional aspects to take into account when mounting your 4115T unit:

- Consider locations of accessories such as AC power outlets and lighting (interior lighting and windows) for installation and maintenance convenience
- Prevent condensation by installing a thermostat-controlled heater or air conditioner
- To allow for maximum cooling, avoid obstructing the airflow

- Place any fans or blowers close to the heat generating devices. If using a fan, make sure that outside air is not brought into the enclosure unless a fabric or other reliable filter is used. This filtration prevents conductive particles and other harmful contaminants from entering the enclosure.
- Do not select a location near equipment that generates excessive electromagnetic interference (EMI) or radio frequency interface (RFI). Examples of these types of equipment are: high power welding machines; induction heating equipment; and large motor starters.
- Place incoming power line devices (such as isolation or constant voltage transformers, local power disconnects, and surge suppressers) away from the system. The proper location of incoming line devices keeps power wire runs as short as possible and minimizes electrical noise transmitted to the unit.
- Make sure the location does not exceed the unit's shock, vibration, and temperature specifications
- Install the unit in the rack or panel in such a way as to ensure that it does not cause a hazard from uneven mechanical loading
- Incorporate a readily-accessible disconnect device in the fixed wiring on permanently connected equipment
- Avoid circuit overloading of the supply circuit

Mechanical Dimensions

Front Panel: 16.14" (410 mm) x 12.16" (309 mm) x 0.315" (8 mm) (WxHxD)

Cabinet: 15.1" (383.6 mm) x 11.13" (282.6 mm) x 3.93" (99 mm) (WxHxD)

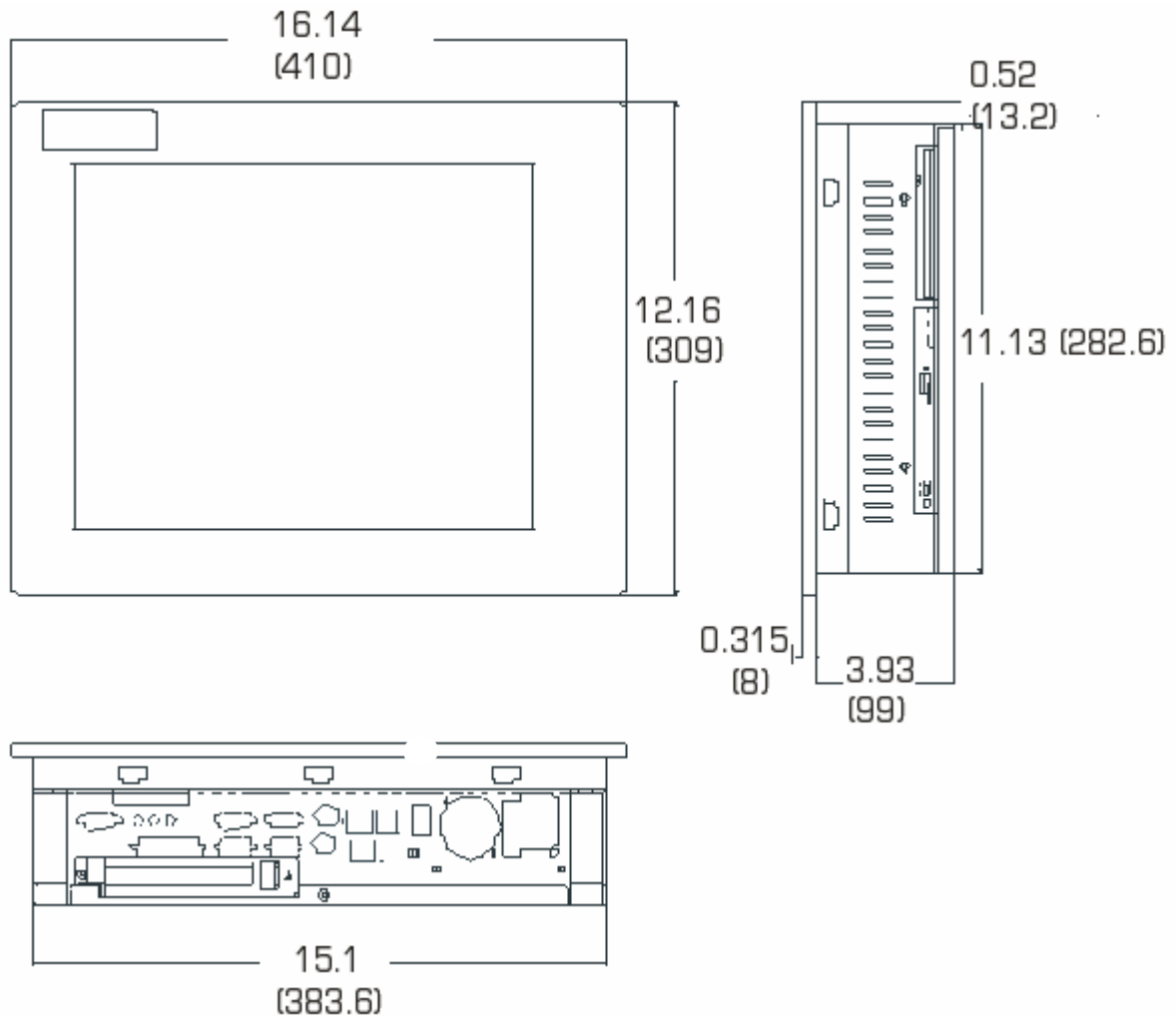

Note: All dimensions in inches (mm)

Figure 2-1. Unit Dimensions

Mounting Options

The 4115T can be mounted to a panel, to the wall, or to an arm. The following sections describe each mounting option for the 4115T.

Panel Mounting

The 4115T is designed for panel mounting. Before mounting the 4115T to the panel, check the cut out dimensions as shown in Figure 2-2. Then, mount it to the panel using ten supporters, as shown in the Figure 2-3 (see next page).

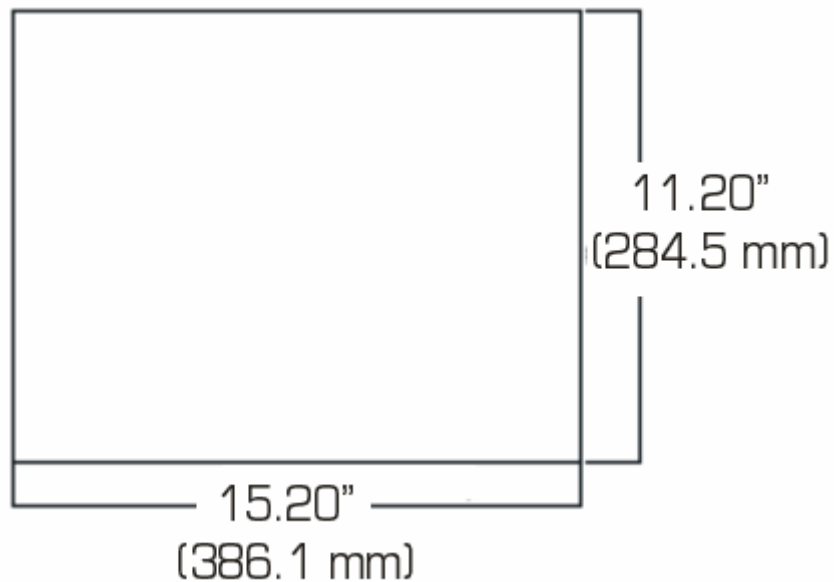

Figure 2-2. Panel Cutout Dimensions

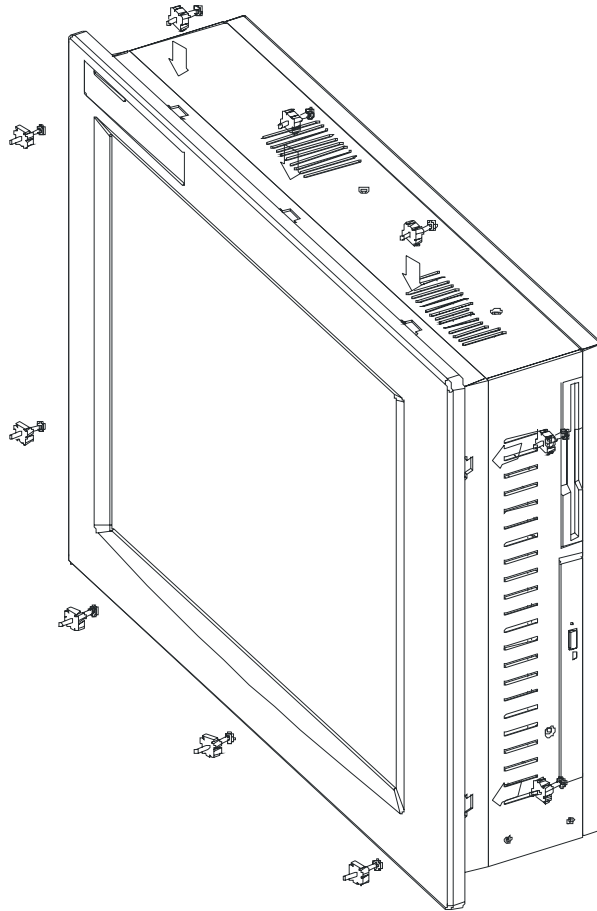
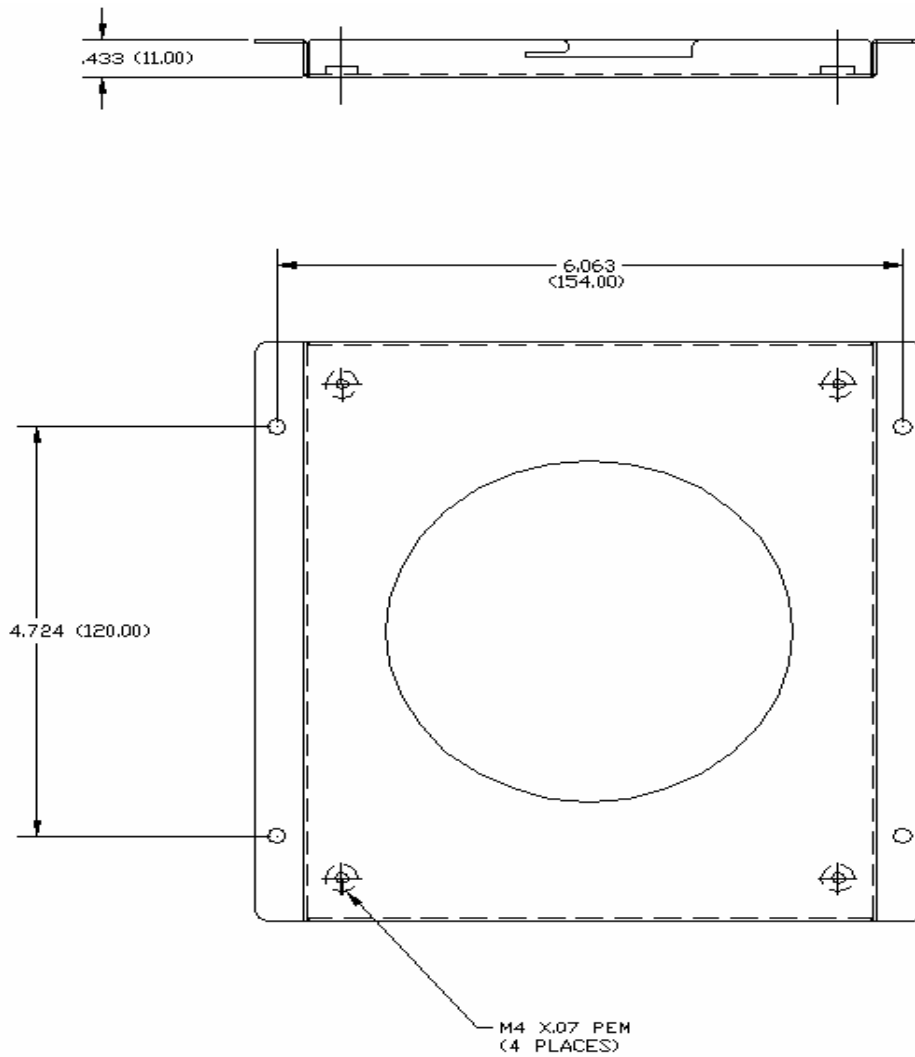

Figure 2-3. Panel Mounting Diagram

Wall Mounting

The 4115T is suitable for wall mount using the included brackets and hardware. See Figure 2-4 for wall mounting dimensions. See Figure 2-5 for a wall-mounting diagram.



All dimensions in inches (mm)

Figure 2-4. Wall Mounting Dimensions

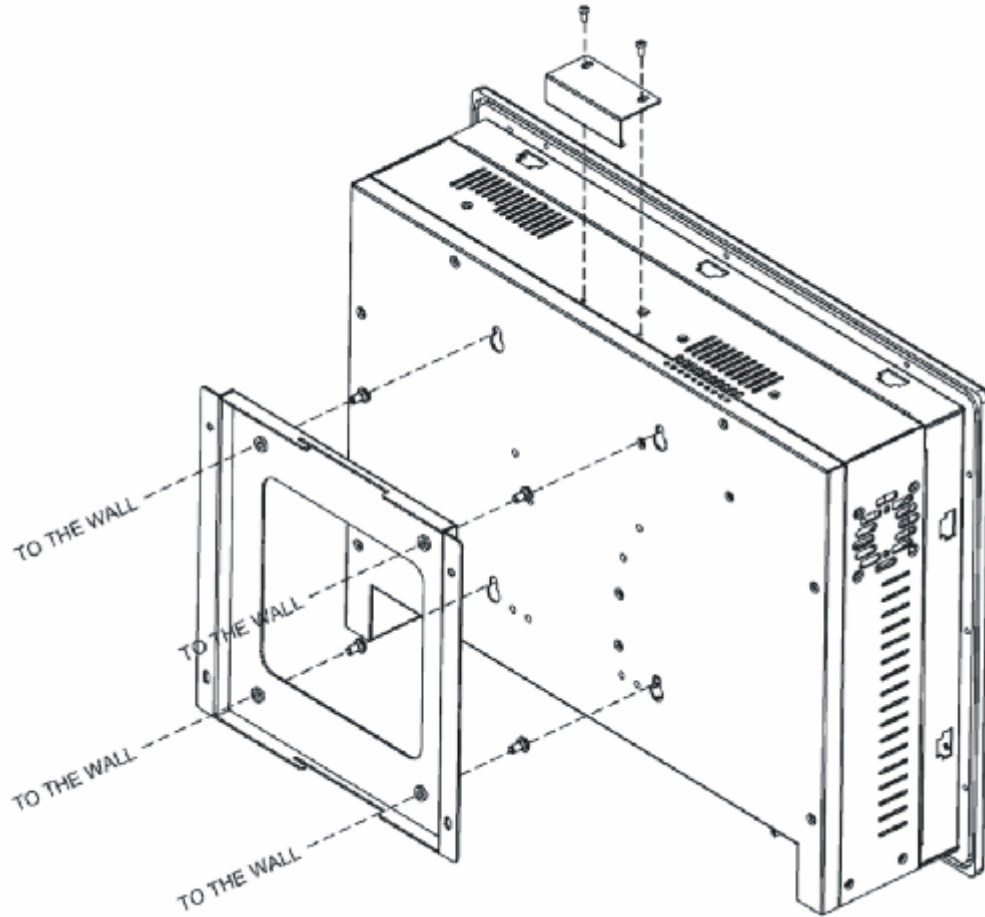
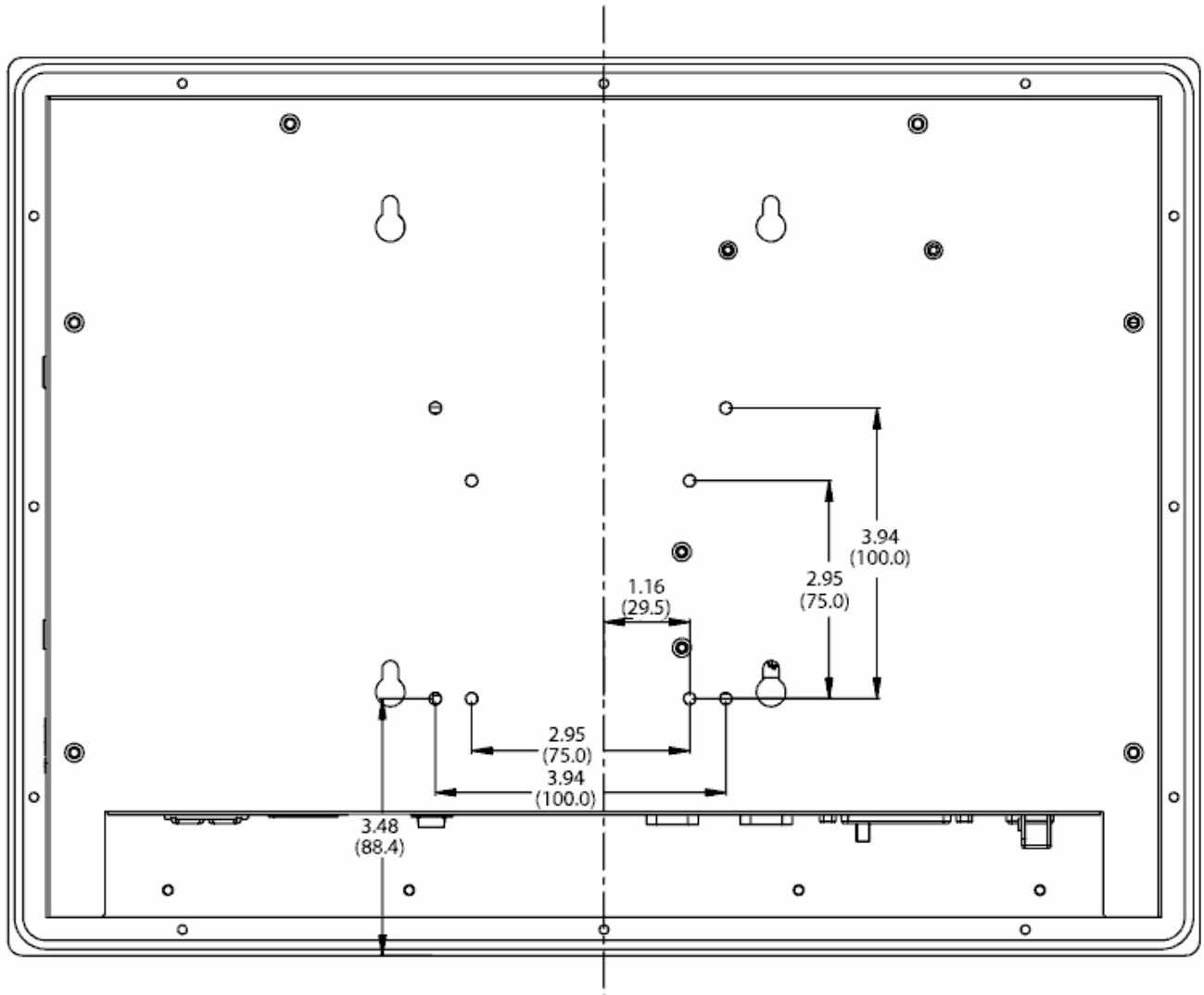

Figure 2-5. Wall Mounting Diagram

Arm Mounting

The 4115T also accommodates 75/100 mm interface pads for arm mounting. Figure 2-6 gives the dimensions for arm mounting.



All dimensions in inches (mm)

Figure 2-6. Arm Mounting Dimensions

Chapter 3 – POS-478 CPU Board and AMI BIOS Setup

POS-478E CPU Board

Product Overview

The 4115T is equipped with a POS-478E Socket 478 Pentium 4 with CPU control board. It is equipped with a high-performance processor and advanced high performance multi-mode I/O.

This board has a built-in AGP4X VGA (Intel 845GV) VGA controller, which shares 8MB or more of system DDR-SDRAM. The on-chip UARTs are compatible with the NS16C550. The parallel port and IDE interface are compatible with IBM PC/AT architecture. The POS-478E also has one 10/100 Fast Ethernet LAN built-in (ICH4).

Specifications

- CPU: Supports Intel Pentium 4 processor, and 400/533MHz FSB.
- Expansion Bus: PCI bus, expansion to support PCI bus signal
- DMA channels: 7
- Interrupt levels: 15
- Chipset: Intel 845GV (GMCH); Intel 82801DB (ICH4) real-time clock
- RAM: Two 184-pin DIMM sockets support DDR 200/266 SDRAM, up to 2GB.
- Built-in AGP2.0 4X 3D graphics engine, which shares system DDR SDRAM 8M or more as needed.
- Up to four PCI enhanced ATA/100 IDE hard drives, which can handle data transfers of up to 100MB/s and are compatible with existing ATA-2 IDE specifications
- Supports up to two floppy disk drives, 5.25" (360KB and 1.2MB) and/or 3.5" (720KB, 1.44MB, and 2.88MB)
- Four serial ports: 16C550 UART (or compatible) with 16-byte FIFO buffer, support up to 115.2Kbps (three ports total external to the 4115T, as one is used for the touch screen)
- Bi-directional parallel port
- Two USB 2.0 ports
- Watchdog timer: Can be set to 1 minute (minimal) or above period.

- AC'97 Audio CODEC
- Compact Flash operates with a passive adapter (True IDE Mode) in a Type I/II Socket
- Wake-Up Function: Supports Wake-On-Lan and Wake-On-Ring.
- Mouse & Keyboard PS/2 Connectors

POS-478E CPU Board Layout

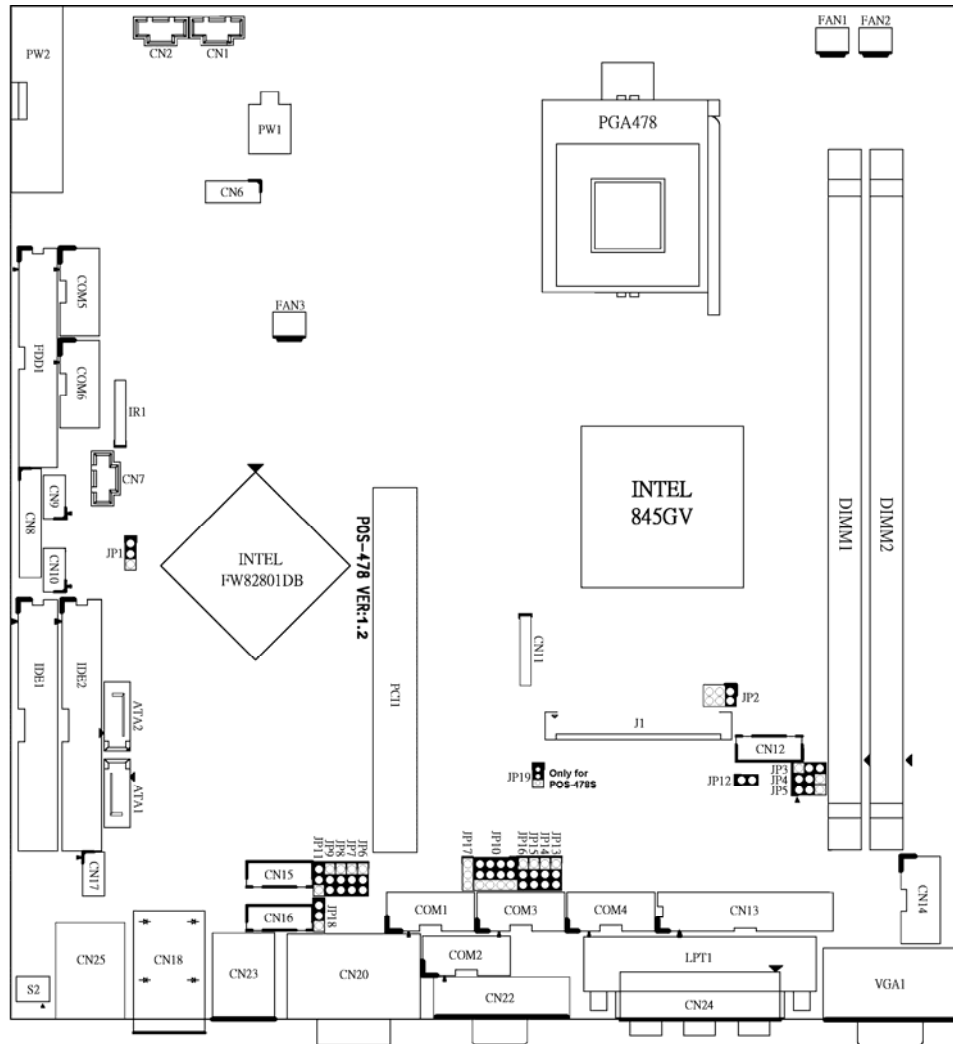

Figure 3-1. POS-478E Board Layout

Note: JP17 is not populated on the POS-478 motherboard.

Caution

Some components on POS-478E are very sensitive to static discharges. To protect it from unintended damage, be sure to follow these precautions:

1. Ground yourself to remove any static charge before touching your POS-478E. You can do it by using a grounded wrist strap at all times or by frequently touching any conducting materials that is connected to the ground.
2. Handle your POS-478E by its edges. Don't touch IC chips, leads or circuitry if not necessary.
3. Do not plug any connector or jumper while the power is on.
4. Do not put your POS-478E unprotected on a flat surface, as the board has components on both sides.

Jumper Settings

The following table lists the functions of all the jumpers on the 4115T. The following sections describe how to set jumpers on the POS-478 board.

Table 3-1. Jumper Functions

Label	Function
JP1	CMOS State Setting
JP2	LCD Voltage Setting
JP3	LCD 24 bit or 18 bit LCD Setting
JP4	LCD CLK Signal Setting
JP5	LCD Single Pixel or Dual Pixel Setting
JP6	Set pin 9 of COM2 Voltage Setting
JP7	Set pin 9 of COM1 Voltage Setting
JP8	Set pin 9 of COM2 as Signal RI or Voltage Setting
JP9	Set pin 9 of COM1 as Signal RI or Voltage Setting
JP10	COM2 Mode Setting
JP11	COM2 Mode RS-232 or RS-422/RS-485 Setting
JP12	Compact Flash Master/Slave Setting
JP13	Set pin 9 of COM3 Voltage Setting
JP14	Set pin 9 of COM4 Voltage Setting
JP15	Set pin 9 of COM3 as Signal RI or Voltage Setting
JP16	Set pin 9 of COM4 as Signal RI or Voltage Setting
JP18	Keyboard & Mouse Power Source Setting
JP19	Enable or Disable Serial ATA (only for POS-478S)

Compact Flash TYPE II Flash Disk Setting

The Compact Flash is 100% compatible to IDE hard disk. It is “plug and play”, easy to use and reliable. The CompactFlashDisk™ is available from 8MB to 1GB.

JP12: CompactFlashDisk™ IDE Master & Slave Setting

PIN	Description
Open	Slave
Short	Master

Clear CMOS Setup

If you forget the CMOS password, you can clear or reset it by closing the JP1. After JP1 (2-3) is closed, turn on the power for about 3 seconds then turn it off and open the JP1 (2-3). Now, the password has been cleared from your CMOS.

JP1: Clear CMOS Setup

PIN	Description
1-2	Normal Operation
2-3	Clear CMOS Setup

COM2 RS-232/422/485 Selection

JP10, JP11: COM2 Mode Selection

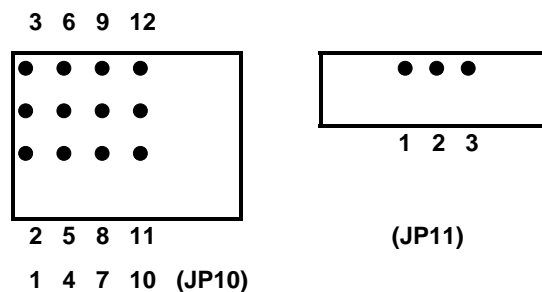

JP10	JP11	Description
1-2,4-5,7-8,10-11	1-2	RS-232
2-3,5-6,8-9,11-12	2-3	RS-422/485

COM Port RI and Voltage Selection**JP7, JP9: Set pin 9 of COM1 as signal RI or voltage source**

JP9	Description
2-3	COM1 RI PIN Use RI
1-2	COM1 RI PIN Use Voltage

JP7	Description
2-3	COM1 RI PIN Use Voltage +12V
1-2	COM1 RI PIN Use Voltage +5V

**The use of JP7 (2-3) or (1-2) will not make any difference when JP9 (2-3) is in use.*

JP6, JP8: Set pin 9 of COM2 as signal RI or voltage source

JP8	Description
2-3	COM2 RI PIN Use RI
1-2	COM2 RI PIN Use Voltage
JP6	Description
2-3	COM2 RI PIN Use Voltage +12V
1-2	COM2 RI PIN Use Voltage +5V

**The use of JP6 (2-3) or (1-2) will not make any difference when JP8 (2-3) is in use.*

JP13, JP15: Set pin 9 of COM3 as signal RI or voltage source

JP15	Description
2-3	COM3 RI PIN Use RI
1-2	COM3 RI PIN Use Voltage

JP13	Description
2-3	COM3 RI PIN Use Voltage +12V
1-2	COM3 RI PIN Use Voltage +5V

**The use of JP13 (2-3) or (1-2) will not make any difference when JP15 (2-3) is in use.*

JP14, JP16: Set pin 9 of COM4 as signal RI or voltage source

JP16	Description
2-3	COM4 RI PIN Use RI
1-2	COM4 RI PIN Use Voltage

JP14	Description
2-3	COM4 RI PIN Use Voltage +12V
1-2	COM4 RI PIN Use Voltage +5V

*The use of JP14 (2-3) or (1-2) will not make any difference when JP16 (2-3) is in use.

Keyboard & Mouse Power Source Setting**JP18: Keyboard & Mouse Power Selection**

JP18	Description
1-2	VCC
2-3	5VSB

LCD Panel Setup

POS-478 provides a highly integrated scaling IC with LVDS Transmitter with a scaled resolution up to SXGA for single pixel Input. The transmitter supports up to 48-bit color TFT LCD.

PANEL MODEL	JP2	JP3	JP4	JP5
LG LP150X1	1-2	2-3	1-2	1-2
ChiMei M170E4	3-4	2-3	1-2	OPEN
Toshiba LTM15C423S	1-2	2-3	1-2	OPEN
Torisan TM121XG-02	1-2	2-3	1-2	1-2
ChiMei M150X3-L04	1-2	2-3	1-2	1-2
LG LM150X06 (A3)	1-2	2-3	1-2	1-2
IMES DM121-53DR	1-2	2-3	1-2	1-2
UniPac UB104S01	1-2	2-3	1-2	1-2
AUO G150XG01 V.0	1-2	2-3	1-2	2-3

JP2: LCD Voltage Setting

JP2	Description
1-2	+3.3V
3-4	+5V
5-6	+12V

JP3: 24-bit or 18-bit LCD Selection (for one pixel). Tie to DVCC to select non-conventional color mapping 24 bit LCD only. Tie to GND to select 18-bit LCD. This setting also is for 24-bit LCD with conventional color mapping.

JP3	Description
2-3	GND
1-2	DVCC

JP4: Tie to DVCC, DS90C2501 will invert CLKINP and CLKINM signals internally. This feature can save PCB layout error by accidentally swap CLKINP and CLKINM pins. Default setting is DVCC.

JP4	Description
1-2	DVCC
2-3	GND

JP5: Tie DUAL pin to DVCC for single pixel in to single pixel out operation. Tie DUAL pin to 1/2 DVCC for single pixel in to dual pixel out operation. This is for LCD requires dual pixel input. Default setting is DVCC.

JP5	Description
1-2	DVCC
2-3	GND
OPEN	1/2 DVCC

Connector Pin Outs

The following describes how to connect peripherals, switches and indicators to POS-478 board.

Floppy Disk Drive Connector

POS-478 board is equipped with a 34-pin daisy-chain drive connector cable.

FDD1: FDD Connector

PIN	Description	PIN	Description
1	GROUND	2	REDUCE WRITE
3	GROUND	4	N/C
5	GROUND	6	N/C
7	GROUND	8	INDEX#
9	GROUND	10	MOTOR ENABLE A#
11	GROUND	12	DRIVE SELECT B#
13	GROUND	14	DRIVE SELECT A#
15	GROUND	16	MOTOR ENABLE B#
17	GROUND	18	DIRECTION#
19	GROUND	20	STEP#
21	GROUND	22	WRITE DATA#
23	GROUND	24	WRITE GATE#
25	GROUND	26	TRACK 0#
27	GROUND	28	WRITE PROTECT#
29	GROUND	30	READ DATA#
31	GROUND	32	SIDE 1 SELECT#
33	GROUND	34	DISK CHANGE#

PCI E-IDE Disk Drive Connector

You can attach four IDE (Integrated Device Electronics) hard disk drives to POS-478 IDE controller.

IDE1, IDE2: Primary, Secondary IDE Connector

IDE1 (Blue), IDE2 (White): IDE Interface Connector

PIN	Description	PIN	Description
1	RESET#	2	GND
3	DATA 7	4	DATA 8
5	DATA 6	6	DATA 9
7	DATA 5	8	DATA 10
9	DATA 4	10	DATA 11
11	DATA 3	12	DATA 12
13	DATA 2	14	DATA 13
15	DATA 1	16	DATA 14
17	DATA 0	18	DATA 15
19	GND	20	N/C
21	IDE DRQ	22	GND
23	IOW#	24	GND
25	IOR#	26	GND
27	IDE CHRDY	28	GND
29	IDE DACK	30	GND
31	INTERRUPT	32	N/C
33	SA 1	34	N/C
35	SA 0	36	SA 2
37	HDC CS0#	38	HDC CS1#
39	HDD ACTIVE#	40	GND

Parallel Port

These ports are usually connected to printer. POS-478 includes two on-board parallel ports, accessed through one 25-pin D-type female connector LPT1 (LPT1) and one 26-pin flat-cable connector CN13 (LPT2).

LPT1: (LPT1 DB-25 Female) Parallel Port Connector

PIN	Description	PIN	Description
1	STROBE#	2	DATA 0
3	DATA 1	4	DATA 2
5	DATA 3	6	DATA 4
7	DATA 5	8	DATA 6
9	DATA 7	10	ACKNOWLEDGE
11	BUSY	12	PAPER EMPTY
13	PRINTER SELECT	14	AUTO FORM FEED #
15	ERROR#	16	INITIALIZE
17	PRINTER SELECT LN#	18	GND
19	GND	20	GND
21	GND	22	GND
23	GND	24	GND
25	GND		

Serial Ports

POS-478 offers four high speed NS16C550 compatible UARTs with Read/Receive 16 byte FIFO serial ports (COM1/COM2/COM3/COM4).

CN20A: Serial Port DB-9 Male Connector (COM1)

PIN	Description
1	DATA CARRIER DETECT (DCD)
2	RECEIVE DATA (RXD)
3	TRANSMIT DATA (TXD)
4	DATA TERMINAL READY (DTR)
5	GROUND (GND)
6	DATA SET READY (DSR)
7	REQUEST TO SEND (RTS)
8	CLEAR TO SEND (CTS)
9	RING INDICATOR (RI)

CN20B: Serial Port DB-9 Male Connector (COM2)

COM2 supports three modes: RS-232, RS-422, RS-485 (For DB-9 Connector)

RS-232 Mode

PIN	Description	PIN	Description
1	DCD	6	DSR
2	RXD	7	RTS
3	TXD	8	CTX
4	DTR	9	RI
5	GND		

RS-422 Mode

PIN	Description	PIN	Description
1	TXD-	6	RX-
2	TXD+	7	RX+
3	NC	8	NC
4	NC	9	Voltage
5	NC		

RS-485 Mode

PIN	Description	PIN	Description
1	RTX-	6	NC
2	RTX+	7	NC
3	NC	8	NC
4	NC	9	Voltage
5	NC		

Keyboard / Mouse Connector

POS-478 provides one keyboard and one mouse header connector, one external keyboard & Mouse connector.

CN23A (Purple): Extended Keyboard 6-pin Mini Din Connector

PIN	Description
1	KB DATA
2	NC
3	GND
4	VCC
5	KB CLOCK
6	NC

CN23B (Green): Extended Mouse 6-pin Mini Din Connector

PIN	Description
1	MS DATA
2	NC
3	GND
4	VCC
5	MS CLOCK
6	NC

External Switches and Indicators

There are several external switches and indicators for monitoring and controlling your CPU board. All the functions are in the CN8 connector.

CN8: Multi Panel

PIN	Description	PIN	Description
1	SPEAKER	11	POWER-VCC
2	ACPI LED	12	N/C
3	N/C	13	GND
4	+5V	14	KEYLOCK
5	RESET SW	15	GND
6	GND	16	GND
7	IDE LED -	17	N/C
8	IDE LED+	18	ATX POWER CONTROL
9	ATX POWER BUTTON	19	ATX 5VSB
10	GND	20	ATX 5VSB

USB Port Connector**N25A: 2 External USB Connectors**

PIN		Description
1	5	VCC
2	6	USB0-
3	7	USB0+
4	8	GND

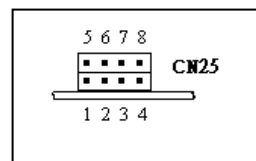

VGA Connector

POS-478 provides one DB-15 female connector and one built-in 10-pin VGA header connector can be connected directly to your monochrome CRT monitor as well as high resolution color CRT monitor.

VGA1: DB-15 Female VGA Connector

PIN	Description	PIN	Description
1	RED	2	GREEN
3	BLUE	4	N/C
5	GND	6	GND
7	GND	8	GND
9	VCC	10	GND
11	N/C	12	DDC DAT
13	HSYNC	14	VSYNC
15	DDC CLK		

LAN RJ45 Connector

POS-478 is equipped with one 10/100Mbps Ethernet Controller (built in INTEL ICH4). You can connect it to your LAN through RJ45 LAN connector. The pin assignments are as follows:

CN17: LAN Link and Active LED Connector

PIN	Description	PIN	Description
1	ICH4_ACT+	2	ICH4_ACT-
3	ICH4_LINK+	4	ICH4_LINK-
5	Intel_ACT+	6	Intel_ACT-
7	Intel_LINK+	8	Intel_LINK-

Fan Connector

POS-478 provides CPU cooling and system fan connectors. These connectors can supply 12V/500mA to the cooling fan.

FAN1: CPU Fan Connector

PIN	Description
1	GND
2	+12V
3	Fan Sensor

FAN2: System Fan Connector

PIN	Description
1	GND
2	+12V
3	Fan Sensor

LCD Backlight Connector

CN12: LCD Backlight Connector

PIN	Description	PIN	Description
1	NC	2	GND
3	+12V	4	GND
5	ENABKL		

LCD Panel LVDS Interface Connector

POS-478 provides a highly integrated scaling IC with LVDS Transmitter with a scaled resolution up to SXGA for single pixel Input. It supports up to 24-bit color TFT LCD.

J1: DF14-30F LVDS Interface Connector

PIN	Description	PIN	Description	PIN	Description
1	GND	2	GND	3	A3P
4	A3M	5	CLK1P	6	CLK1M
7	A2P	8	A2M	9	A1P
10	A1M	11	A0P	12	A0M
13	GND	14	GND	15	A7P
16	A7M	17	CLK2P	18	CLK2M
19	A6P	20	A6M	21	A5P
22	A5M	23	A4P	24	A4M
25	GND	26	GND	27	LCD_VDD
28	LCD_VDD	29	LCD_VDD	30	LCD_VDD

Audio Connector**CN7: Audio CD IN (2.54mm)**

PIN	Description	PIN	Description
1	CD IN_L	2	GND
3	GND	4	CD IN_R

CN1: Audio AUX IN (2.54mm)

PIN	Description	PIN	Description
1	AUX IN_L	2	GND
3	GND	4	AUX IN_R

CN2: Audio LINE OUT (2.54mm)

PIN	Description	PIN	Description
1	LINEOUT_L	2	GND
3	GND	4	LINE OUT_R

CN24: Audio Jack

Color	Description
RED	MIC IN
BLUE	LINE IN
GREEN	SPEAK OUT

Internal Switches and Indicators

There is one internal switch controlling your CPU board.

S2: Reset Switch

PIN	Description	PIN	Description
1	Reset	2	GND

CompactFlash TYPE II Storage Card Socket

POS-478 configures CompactFlash TYPE II Storage Card in IDE Mode.

Note: Type I storage cards are supported.

CFA1: CompactFlash TYPE II Socket PIN Assignment

PIN	Description	PIN	Description
1	GROUND	26	CARD DETECT1
2	D3	27	D11
3	D4	28	D12
4	D5	29	D13
5	D6	30	D14
6	D7	31	D15
7	CS1#	32	CS3#
8	N/C	33	N/C
9	GROUND	34	IOR#
10	N/C	35	IOW#
11	N/C	36	OBLIGATORY TO PULL HIGH
12	N/C	37	IRQ15
13	VCC	38	VCC
14	N/C	39	MASTER/SLAVE
15	N/C	40	N/C
16	N/C	41	RESET#
17	N/C	42	IORDY
18	A2	43	N/C
19	A1	44	OBLIGATORY TO PULL HIGH
20	A0	45	ACTIVE#
21	D0	46	PDIAG#
22	D1	47	D8
23	D2	48	D9
24	N/C	49	D10
25	CARD DETECT2	50	GROUND

ATX Power Connector

PW2 is a 20-pin ATX Power Supply Connector. Please refer to the following table for the pin assignments.

PW2: ATX Power Supply Connector

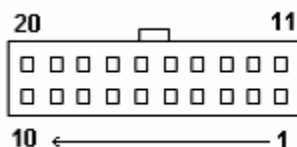

PIN	Description	PIN	Description
11	3.3V	1	3.3V
12	-12V	2	3.3V
13	GND	3	GND
14	PS-ON	4	+5V
15	GND	5	GND
16	GND	6	+5V
17	GND	7	GND
18	-5V	8	Power good
19	+5V	9	5VSB
20	+5V	10	+12V

ATX-12V Power Connector

This connector supports the ATX power, functions such as modem Ring on, and wake-up LAN and soft power off are supported by mainboard.

PW1: ATX-12V Power Connector

PW1			
PIN	Description	PIN	Description
1	GND	2	GND
3	+12V	4	+12V

Note

The power from PW1 should support at least 6.5A current for the use of P4 CPU. If the power is not enough, the operation of CPU could be abnormal. Be sure the power from power supply is enough, and don't share this power with other devices, such as hard disk etc. You can use ICP's special cable for connection if your power supply doesn't have suitable cable.

AMI BIOS Setup

This section describes the AMI Setup program built into the ROM BIOS. The setup program allows users to modify the basic system configuration. This special information is then stored in battery-backed RAM so that it retains the Setup information when the power is turned off.

Starting Setup

The AMI BIOS is immediately activated when you first power on the computer. The BIOS reads the system information contained in the CMOS and begins the process of checking out the system and configuring it. When it finishes, the BIOS will seek an operating system on one of the disks and then launch and turn control over to the operating system.

While the BIOS is in control, the Setup program can be activated in one of two ways:

1. By pressing immediately after switching the system on, or
2. By pressing the key when the following message appears briefly at the bottom of the screen during the POST (Power On Self Test).

Press DEL to enter SETUP.

If the message disappears before you respond and you still wish to enter Setup, restart the system to try again by turning it OFF then ON or pressing the "RESET" button on the system case. You may also restart by simultaneously pressing <Ctrl>, <Alt>, and <Delete> keys. If you do not press the keys at the correct time and the system does not boot, an error message will be displayed and you will again be asked to...

PRESS F2 TO CONTINUE, DEL TO ENTER SETUP

Using Setup

In general, you use the arrow keys to highlight items, press Enter to select, use the PgUp and PgDn keys to change entries, press F1 for help and press Esc to quit. The following table provides more detail about how to navigate in the Setup program using the keyboard.

Table 3-2. Using Setup

Keys	Description
Up arrow	Move to previous item
Down arrow	Move to next item
Left arrow	Move to the item in the left hand
Right arrow	Move to the item in the right hand
Esc key	Main Menu -- Quit and not save changes into CMOS Status Page Setup Menu and Option Page Setup Menu -- Exit current page and return to Main Menu
PgDn key	Increase the numeric value or make changes
PgUp key	Decrease the numeric value or make changes
+ key	Increase the numeric value or make changes
- key	Decrease the numeric value or make changes
F1 key	General help, only for Status Page Setup Menu and Option Page Setup Menu
F2 /F3 key	Change color from total 16 colors. F2 to select color forward, (Shift) F2 to select color backward
F4 key	Reserved
F5 key	Reserved
F6 key	Reserved
F7 key	Reserved
F8 key	Reserved
F9 key	Reserved
F10 key	Save all the CMOS changes, only for Main Menu

Getting Help

Press F1 to pop up a small help window that describes the appropriate keys to use and the possible selections for the highlighted item. To exit the Help Window press Esc or the F1 key again. Note: For this BIOS, Help has been disabled.

If, after making and saving system changes with Setup, you discover that your computer no longer is able to boot, the AMI BIOS supports an override to the CMOS settings, which resets your system to its defaults.

The best advice is to only alter settings that you thoroughly understand. To this end, we strongly recommend that you avoid making any changes to the chipset defaults.

These defaults have been carefully chosen by both AMI and your systems manufacturer to provide the absolute maximum performance and reliability. Even a seemingly small change to the chipset setup has the potential for causing you to use the override.

Main Menu

Once you enter the AMIBIOS™ CMOS Setup Utility, the Main Menu will appear on the screen. The Main Menu allows you to select from several setup functions and two exit choices. Use the arrow keys to select among the items and press Enter to accept and enter the sub-menu.

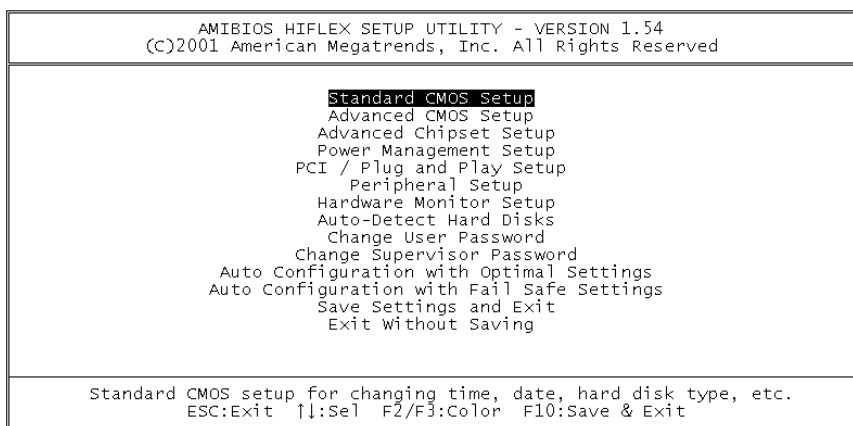

Figure 3-2. AMIBIOS HIFLEX Setup Utility

Note: A brief description of each highlighted selection appears at the bottom of the screen.

Setup Utility Selections

The main menu includes the main setup categories listed in the following table. Note that some systems may not include all entries.

Item	Description
Standard CMOS Setup	Use this menu for basic system configuration.
Advanced CMOS Setup	Use this menu to set the Advanced Features available on your system.
Advanced Chipset Setup	Use this menu to change the values in the chipset registers and optimize your system's performance.
Power Management Setup	When Disabled, SMI will not be initialized, and complete power management functionality is removed until this option is set to Enabled.
PCI / Plug and Play Setup	This entry appears if your system supports PnP / PCI.
Peripheral Setup	Use this menu to specify your settings for integrated peripherals.

Item	Description
Hardware Monitor Setup	Use this menu to monitor your hardware.
Auto-detect Hard Disks	Use this menu to specify your settings for hard disks control.
Change User Password	Use this menu to set User Password.
Change Supervisor Password	Use this menu to set Supervisor Password.
Auto Configuration with Optimal Settings	Use this menu to load the BIOS default values that are factory settings for optimal performance system operations. While AMI has designed the custom BIOS to maximize performance, the factory has the right to change these defaults to meet their needs.
Auto Configuration with Fail-Safe Settings	Use this menu to load the BIOS default values for the minimal/stable performance for your system to operate.
Save Settings and Exit	Save CMOS value changes to CMOS and exit setup.
Exit Without Saving	Abandon all CMOS value changes and exit setup.

Standard CMOS Setup

The items in Standard CMOS Setup Menu are divided into 12 categories. Each category includes no, one or more than one setup items. Use the arrow keys to highlight the item and then use the PgUp or PgDn keys to select the value you want in each item.

AMIBIOS SETUP - STANDARD CMOS SETUP							
(c)2001 American Megatrends, Inc. All Rights Reserved							
Date (mm/dd/yyyy):	Tue Apr 22, 2003	Base Memory:	0 KB				
Time (hh/mm/ss) :	15:30:55	Extd Memory:	0 MB				
Floppy Drive A:	1.44 MB 3½						
Floppy Drive B:	Not Installed						
	Type	Size	Cyl'n	Head	WPcom	Sec	LBA Blk PIO 32Bit Mode Mode Mode Mode
Pri Master:	Auto						On
Pri Slave :	Auto						On
Sec Master:	Auto						On
Sec Slave :	Auto						On
Boot Sector Virus Protection	Disabled						
Month:	Jan - Dec	ESC:Exit	↑↓:Sel				
Day:	01 - 31	PgUp/PgDn:	Modify				
Year:	1980 - 2099	F1:Help	F2/F3:Color				

Figure 3-3. Standard CMOS Features

Table 3-4. Standard CMOS Setup Items

Item	Options	Description
Date	MM DD YYYY	Set the system date.
Time	HH : MM : SS	Set the system time
IDE Primary Master	Options are in its sub menu	Press <Enter> to enter the sub menu of detailed options
IDE Primary Slave	Options are in its sub menu	Press <Enter> to enter the sub menu of detailed options
IDE Secondary Master	Options are in its sub menu	Press <Enter> to enter the sub menu of detailed options
IDE Secondary Master	Options are in its sub menu	Press <Enter> to enter the sub menu of detailed options
Floppy Drive A Floppy Drive B	None 360K, 5.25 in 1.2M, 5.25 in 720K, 3.5 in 1.44M, 3.5 in 2.88M, 3.5 in	Select the type of floppy disk drive installed in your system.
Boot Sector Virus protection	Disabled Enabled	All it does is warn you when attempts are made to write to your boot sector or partition table.
Base Memory	N/A	Displays the amount of conventional memory detected during boot up
Extended Memory	N/A	Displays the amount of extended memory detected during boot up

Advanced CMOS Setup

This section allows you to configure your system for basic operation. You have the opportunity to select the system's default speed, boot-up sequence, keyboard operation, shadowing and security.

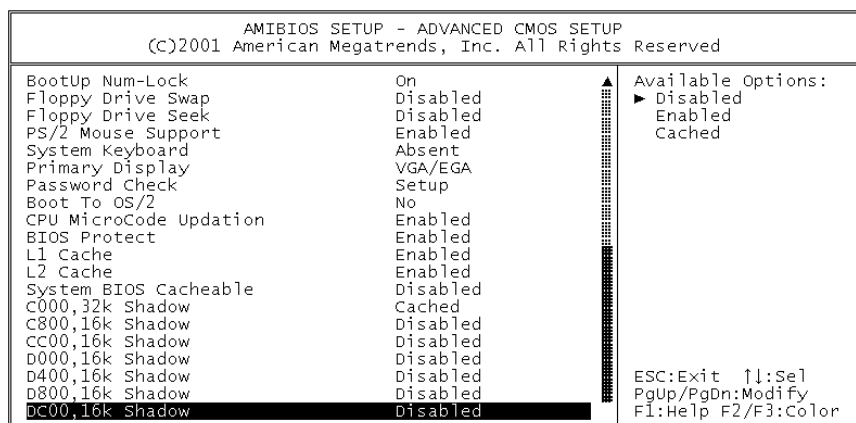
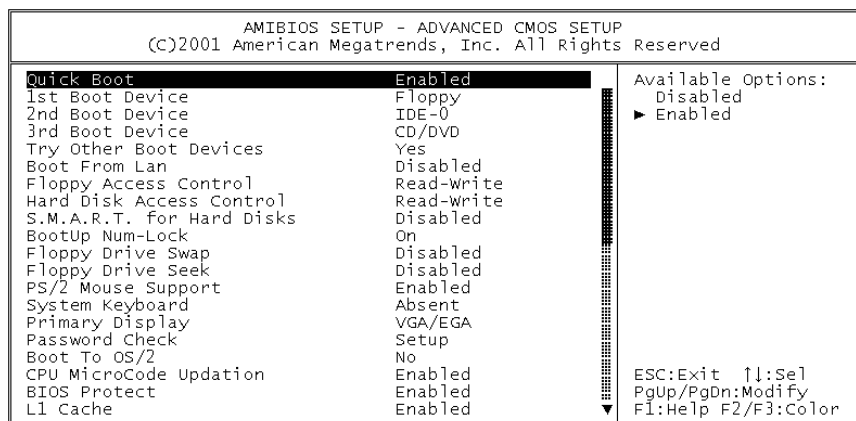

Figure 3-4. Advanced CMOS Setup

Note: the second screen capture shows the last 9 items in the Advanced CMOS Setup screen.

Item	Description
Quick Boot	When set to Enabled, DRAM testing function will be disabled.
1st /2nd /3rd Boot Device	This option sets the type of device for the first boot drives that the AMIBIOS attempts to boot from after AMIBIOS POST completes. The settings are Disabled, IDE-0, Floppy, GD/DVD.
Try Other Boot Devices	Set this option to Yes to instruct AMIBIOS to attempt to boot from any other drive in the system if it cannot find a boot drive among the drives specified in the 1st Boot Device, 2nd Boot Device, 3rd Boot Device, 4th Boot Device

Item	Description
	options. The settings are Yes or No.
Boot From LAN	Set to Enabled to the system boot from LAN.
Floppy Access Control	This option specifies the read/write access that is set when booting from a floppy drive. The settings are Read/Write or Read-Only.
Hard Disk Access Control	This option specifies the read/write access that is set when booting from a hard disk drive. The settings are Read/Write or Read-Only.
S.M.A.R.T. for Hard Disks	Self-Monitoring, Analysis and Reporting Technology. This option can help BIOS to warn the user of the possible device failure and give user a chance to back up the device before actual failure happens. The settings are Disabled, Enabled.
Boot Up Num-Lock	When on, this option turns off Num Lock when the system is powered on so the end user can use the arrow keys on both the numeric keypad and the keyboard
Floppy Drive Swap	Set this option to Enabled to permit drives A: and B: to be swapped. The settings are Enabled or Disabled.
Floppy Drive Seek	Set this option to Enabled to specify that floppy drives A: will perform a Seek operation at system boot. The settings are Enabled or Disabled.
PS/2 Mouse Support	When this option is enabled, BIOS support a PS/2- type mouse.
System Keyboard	This option does not specify if a keyboard is attached to the computer. It specifies if error messages are displayed if a keyboard is not attached. This option permits you to configure workstation with no keyboard. The settings are Absent, Present.
Primary Display	Select this option to configure the type of monitor attached to the computer. The settings are Monochrome, Color 40x25, Color 80x25, VGA/PGA/EGA, or Not Install.
Password Check	This option enables the password check option every time the system boots or the end user runs Setup. If always is chosen a user password prompt appears every time the computer is tuned on. If setup is chosen, the password prompt appears if BIOS is executed.
Boot To OS/2	Set this option to Enabled if running OS/2 operating system and using more than 64MB of system memory on the motherboard. The settings are YES or NO.
BIOS Protect	Set this option to Disabled when you want to flash BIOS

Item	Description
L1 Cache	The option enabled or disabled the internal cache memory in the processor
L2 Cache	The option enables secondary cache memory. Select Enabled to enable external cache memory, vice versa.
System BIOS Cacheable	When this option is set to Enabled, the System ROM area from F0000- FFFFF is copied (shadowed) to RAM for faster execution.
C000, 32k Shadow	When this option is set to Enabled, the Video ROM area from C0000- C7FFF is copied (shadowed) to RAM for faster execution. Disabled: The contents of the video ROM are not copied to RAM. Cached: The contents of the video ROM area from C0000h - C7FFFh are copied from ROM to RAM and can be written to or read from cache memory. Enabled: The contents of the video ROM area from C0000h–C7FFFh are copied (shadowed) from ROM to RAM for faster execution.
C800, 16k Shadow	These options enable shadowing of the contents of the ROM area named in the option title. The settings are Enable Disable, Cached. The ROM area that is not used by ISA adapter cards will be allocated to PCI adapter cards.000, 32k Shadow.
CC00, 16k Shadow	These options enable shadowing of the contents of the ROM area named in the option title. The settings are Enable Disable, Cached. The ROM area that is not used by ISA adapter cards will be allocated to PCI adapter cards.800, 16k Shadow.
D000, 16k Shadow	These options enable shadowing of the contents of the ROM area named in the option title. The settings are Enable Disable, Cached. The ROM area that is not used by ISA adapter cards will be allocated to PCI adapter cards. C00, 16k Shadow.
D400, 16k Shadow	These options enable shadowing of the contents of the ROM area named in the option title. The settings are Enable Disable, Cached. The ROM area that is not used by ISA adapter cards will be allocated to PCI adapter cards.000, 16k Shadow.
D800, 16k Shadow	These options enable shadowing of the contents of the ROM area named in the option title. The settings are Enable Disable, Cached. The ROM area that is not used by ISA adapter cards will be allocated to PCI adapter cards.400, 16k Shadow.
DC00, 16k Shadow	These options enable shadowing of the contents

Item	Description
	of the ROM area named in the option title. The settings are Enable Disable, Cached. ISA adapter cards will be allocated to PCI adapter cards.800, 16k Shadow.

Advanced Chipset Setup

This section allows you to configure the system based on the specific features of the installed chipset. This chipset manages bus speeds and access to system memory resources, such as DRAM and the external cache. It also coordinates communications between the conventional ISA bus and the PCI bus. It must be stated that these items should never need to be altered. The default settings have been chosen because they provide the best operating conditions for your system.

AMIBIOS SETUP - ADVANCED CHIPSET SETUP (C)2001 American Megatrends, Inc. All Rights Reserved	
***** DRAM Timing *****	Available Options: Disabled ▶ Enabled
SDRAM Frequency 133Mhz	
Configure SDRAM Timing by SPD Enabled	
SDRAM CAS# Latency 3 Clocks	
SDRAM RAS# Precharge 3 Clocks	
SDRAM RAS# to CAS# Delay 3 Clocks	
SDRAM Precharge Delay 7 Clocks	
SDRAM Burst Length 4	
Memory Hole Disabled	
Hyper Threading Function Disabled	
Internal Graphics Mode Select 8MB	
AGP Aperture Size 64MB	
USB Controller 2 USB Ports	
USB 1.1 Device Legacy Support Disabled	
USB 1.1 Port 64/60 Emulation Disabled	
***** Display Setting *****	
Boot Display Device CRT	ESC:Exit ↑:Sel
Flat Panel Type 1 800x600 LVDS	PgUp/PgDn:Modify F1:Help F2/F3:Color

Figure 3-5. Advanced Chipset Setup

Item	Description
SDRAM Frequency	This setting is decided by Memory frequency.
Configure SDRAM Timing by SPD	This field detects the capability of the SDRAM modules that you are using -Enabled or Disabled.
SDRAM CAS# Latency	This controls the latency between the SDRAM read command and the time that the data actually becomes available.
Memory Hole	You can reserve this area of system memory for ISA adapter ROM. When this area is reserved, it cannot be cached. The user information of peripherals that need to use this area of system memory usually discusses their memory requirements.

Table 3-6. Advanced Chipset Setup Options

Item	Description
Hyper Threading Function	Set this option to Enabled to use INTEL Hyper Threading Function.
Internal Graphics Mode Select	This option is setting for sharing memory size from system memory to Video memory.
USB Controller	This option is setting for USB 2.0 controller. You can select 2 USB ports, 4 USB ports, 6 USB ports and Disabled.
Boot Display Device	This option is setting for display output from CRT or CRT & LFP.
Flat Panel Type	This option is setting for panel resolution. The selections include 800 x 600 LVDS, 1024 x 768 LVDS and 1280 x 1024 LVDS.
USB 1.1 Device Legacy Support USB 1.1 Port 64/60 Emulation	These parameters are used to enable a USB keyboard, mouse and floppr at boot time. (Note: Mouse still needs PS/2 mouse driver).

Power Management Setup

AMIBIOS SETUP - POWER MANAGEMENT SETUP (C)2001 American Megatrends, Inc. All Rights Reserved		
ACPI Aware O/S (S1)	Yes	Available Options: No ▶ Yes ESC:Exit ↑↓:Sel PgUp/PgDn:Modify F1:Help F2/F3:Color
Re-Call VGA BIOS at S3 Resuming	Enabled	
Power Management/APM	Enabled	
Video Power Down Mode	Disabled	
Hard Disk Power Down Mode	Disabled	
Standby Time Out (Minute)	Disabled	
Suspend Time Out (Minute)	Disabled	
Primary Master IDE	Monitor	
Primary Slave IDE	Ignore	
Secondary Master IDE	Monitor	
Secondary Slave IDE	Ignore	
Power Button Function	On/Off	
Restore on AC/Power Loss	Last State	
Resume On Ring	Disabled	
Resume On LAN	Disabled	
Resume On PME#	Disabled	
Resume On RTC Alarm	Disabled	
RTC Alarm Date	15	
RTC Alarm Hour	12	
RTC Alarm Minute	30	

AMIBIOS SETUP - POWER MANAGEMENT SETUP (C)2001 American Megatrends, Inc. All Rights Reserved		
Power Management/APM	Enabled	Available Options: AT ▶ ATX ESC:Exit ↑↓:Sel PgUp/PgDn:Modify F1:Help F2/F3:Color
Video Power Down Mode	Disabled	
Hard Disk Power Down Mode	Disabled	
Standby Time Out (Minute)	Disabled	
Suspend Time Out (Minute)	Disabled	
Primary Master IDE	Monitor	
Primary Slave IDE	Ignore	
Secondary Master IDE	Monitor	
Secondary Slave IDE	Ignore	
Power Button Function	On/Off	
Restore on AC/Power Loss	Last State	
Resume On Ring	Disabled	
Resume On LAN	Disabled	
Resume On PME#	Disabled	
Resume On RTC Alarm	Disabled	
RTC Alarm Date	15	
RTC Alarm Hour	12	
RTC Alarm Minute	30	
RTC Alarm Second	30	
Power Type Select	ATX	

Figure 3-6. Power Management Setup

Table 3-7. Power Management Setup Options	
Item	Description
ACPI Aware O/S	This feature is switch of ACPI function. Configuration option: [Yes] or [No].
Power Management/APM	When Disabled, SMI will not be initialized, and complete power management functionality is removed until this option is set to Enabled.
Suspend Time Out (Minute)	If no activity occurs during this time period, BIOS will place the system into suspend low power state. The "Standby Time Out" period must expire first (if enabled) before this time out period begins.
Resume on Ring	Modem ring resumes from soft off.
RTC Alarm Date, Hour, Minute	When this option is set enabled, system will wake up from soft off mode according to your set time.

Item	Description
Power Type Select	This feature is switch of Power Type function. Configuration options: [AT] [ATX]

PCI / Plug and Play Setup

AMIBIOS SETUP - PCI / PLUG AND PLAY SETUP (C)2001 American Megatrends, Inc. All Rights Reserved		
Clear NVRAM	No	Available Options: ▶ No Yes
PCI Latency Timer (PCI Clocks)	64	
Init. Graphics Adapter Priority	PCI/Int-VGA	
PCI VGA Palette Snoop	Disabled	
Allocate IRQ to PCI VGA	Yes	
OffBoard PCI IDE Card	Auto	
OffBoard PCI IDE Primary IRQ	Disabled	
OffBoard PCI IDE Secondary IRQ	Disabled	
PCI Slot1 IRQ Priority	Auto	
PCI Slot2 IRQ Priority	Auto	
PCI Slot3 IRQ Priority	Auto	
PCI Slot4 IRQ Priority	Auto	
ESC:Exit ↑↓:Sel PgUp/PgDn:Modify F1:Help F2/F3:Color		

Figure 3-7. PCI/Plug and Play Setup

Item	Description
Clear NVRAM	When this option is set to Yes, system can auto clear NVRAM. The settings are Yes or No.
PCI Latency Timer (PCI Clocks)	This option specifies the latency timings (in PCI clocks) for PCI devices installed in the PCI expansion slots. The settings are 32, 64, 96, 128, 160, 192, 224, or 248.
Init. Graphics Adapter Priority	This setting is to select primary graphic by PCI or AGP Adapter.
Allocate IRQ to PCI VGA	Set this option to Yes to allocate an IRQ to the VGA device on the PCI bus. The settings are Yes or No.
OffBoard PCI IDE Card	This question is needed for off-board non-compliant PCI IDE card. If present, BIOS needs to know which slot it is in and how the IRQ is used by the card.
OffBoard PCI IDE Primary IRQ	This option specifies the PCI interrupt used by the primary IDE channel on the offboard PCI IDE controller. The settings are Disabled, Hardwired, INTA, INTB, INTC, or INTD.
OffBoard PCI IDE Secondary IRQ	This option specifies the PCI interrupt used by the secondary IDE channel on the offboard PCI IDE controller. The settings are Disabled, Hardwired, INTA, INTB, INTC, or INTD.
PCI Slot1 / Slot2 / Slot3 / Slot4 IRQ	The option specifies the IRQ priority for PCI

Item	Description
Priority	device installed in the PCI expansion slot. The settings are Auto, (IRQ) 3, 4, 5, 7, 9, 10, and 11, in priority order.

Peripheral Setup

The Peripheral Setup allows you to configure you system to most effectively save energy while operating in a manner consistent with your own style of computer use.

AMIBIOS SETUP - PERIPHERAL SETUP (C)2001 American Megatrends, Inc. All Rights Reserved		
OnBoard IDE	Both	Available Options: Disabled Primary Secondary ▶ Both ESC:Exit ↑:Sel PgUp/PgDn:Modify F1:Help F2/F3:Color
OnBoard LAN	Enabled	
OnBoard AC'97 Audio	Enabled	
OnBoard FDC	Enabled	
OnBoard Serial Port1	3F8/COM1	
OnBoard Serial Port2	2F8/COM2	
Serial Port2 Mode	Normal	
OnBoard Parallel Port	378	
Parallel Port Mode	Normal	
Parallel Port IRQ	7	
Parallel Port DMA Channel	N/A	
OnBoard Serial Port C	3E8/COM3	
Serial Port C IRQ	11	
OnBoard Serial Port D	2E8/COM4	
Serial Port D IRQ	10	
OnBoard Parallel Port 2	Disabled	
Parallel Port 2 IRQ	N/A	

Figure 3-8. Peripheral Setup Options

Item	Description
OnBoard LAN	This option is setting to enable or disable Onboard LAN Function.
OnBoard AC'97 Audio	This option is setting to enable or disable Onboard AC'97 Audio Function
OnBoard FDC.	This option is setting to enable or disable Onboard FDC Function.
OnBoard Serial Port 1 /Port 2 /Port C /Port D	This option specifies the base I/O port address of serial port 1. The settings are Auto (AMIBIOS automatically determines the correct base I/O port address), Disabled, 3F8h, 2F8h, 2E8h, or 3E8h.
Serial Port2 Mode	This option specifies the IR active pulse or inverting clock of serial port B.
OnBoard Parallel Port1 /Port2	This option specifies the base I/O port address of parallel port on the motherboard. The settings are Disabled, 378h, 278h, or 3BCh.

Item	Description
Parallel Port Mode	This option specifies the parallel port mode. The settings are Normal, Bi-Dir, EPP, and ECP. Normal: The normal parallel port mode is used. Bi-Dir: Use this setting to support bi-directional transfers on the parallel port. EPP: The parallel port can be used with devices that adhere to the Enhanced Parallel Port (EPP) specification. EPP uses the existing parallel port signals to provide asymmetric bi-directional data transfer driven by the host device. ECP: The parallel port can be used with devices that adhere to the Extended Capabilities Port (ECP) specification. ECP uses the DMA protocol to achieve data transfer rates up to 2.5 Megabits per second. ECP provides symmetric bi-directional communication.
EPP Version	EPP data or address read cycle 1.9 or 1.7
Parallel Port /Port2 IRQ	This option specifies the IRQ used by the parallel port. The settings are Auto, (IRQ) 5, (IRQ) 7.
Parallel Port DMA Channel	This option is only available if the setting for the Parallel Port Mode option is ECP. This option sets the DMA channel used by the parallel port. The settings are DMA Channel 0, 1, or 3.

Hardware Monitor Setup

AMIBIOS SETUP - HARDWARE MONITOR SETUP (C)2001 American Megatrends, Inc. All Rights Reserved	
--== System Hardware Monitor ==--	
CPU Case Temperature	15 °C/59°F
System Temperature	38 °C/100°F
Fan_1 Speed	0 RPM
Fan_2 Speed	4200 RPM
Vcore	1.488V
+1.5V	1.488V
+3.3V	3.344V
+ 5.0V	5.278V
+12.0V	12.048V
-12.0V	-12.203V
- 5.0V	-4.993V
+5V SB	5.278V
Battery	2.864V
ESC:Exit ↑:Sel PgUp/PgDn:Modify F1:Help F2/F3:Color	

Figure 3-9. Hardware Monitor Setup Options

Table 3-10. Hardware Monitor Setup Options

Item	Description
<p>Change Supervisor Password</p> <p>Supervisor password:</p> <p>User password:</p>	<p>You can set either supervisor or user password, or both of them. The differences between are:</p> <p>To enter and change the options of the setup menus.</p> <p>To enter the setup menus only but do not have the right to change the options. When you select this function, the following message will appear at the center of the screen to assist you in creating a password.</p>
<p>Enter Password</p>	<p>Type the password, up to eight characters in length, and press <Enter>. The password typed now will clear any previously entered password from CMOS memory. You will be asked to confirm the password. Type the password again and press <Enter>. You may also press <Esc> to abort the selection and not enter a password.</p> <p>To disable a password, just press <Enter> when you are prompted to enter the password. A message will confirm the password will be disabled. Once the password is disabled, the system will boot and you can enter Setup freely.</p>
<p>Password Disabled</p>	<p>When a password has been enabled, you will be prompted to enter it every time you try to enter Setup. This prevents an unauthorized person from changing any part of your system configuration. Additionally, when a password is enabled, you can also require the BIOS to request a password every time your system is rebooted. This would prevent unauthorized use of your computer.</p> <p>You determine when the password is required within the BIOS Features Setup Menu and its Security option (see Section 3). If the Security option is set to "Always", password will be required both at boot and at entry to Setup. If set to "Setup", prompting only occurs when trying to enter Setup.</p>

Chapter 4 – Maintenance

The 4115T is designed to withstand the harsh environment of the factory floor. Routine maintenance can help keep your system in good operating condition. Preventive maintenance consists of several basic procedures that will greatly reduce the chance of system malfunction. Schedule preventive maintenance along with the regular equipment maintenance to minimize down time.

General Preventive Maintenance

Here are some preventive measures you can take:

- Clean the monitor screen using a non-residue cleaner such as a mild window cleaning solution or CRT screen cleaner. Take care not to scratch the screen face.
- *Remove dust and dirt from PC components.* If dust builds up on heat sinks and circuitry, an obstruction of heat dissipation could cause the unit to malfunction. If dust reaches the electronic boards, a short circuit could occur.
- *Check the connections to I/O modules,* especially in environments where vibration could loosen the connections. Check to see that all plugs, sockets, terminal strips, and module connections are solid.
- *Remove unnecessary articles, such as drawings or manuals, from the unit.* They can obstruct airflow and create hot spots, which cause the system to malfunction.
- *Do not place noise-generating equipment near the 4115T unit.*

Fuse Replacement

The 4115T unit has no accessible fuse. Return the unit to the factory for fuse replacement.

Recommended Hard Drive Preventive Maintenance

Xycom Automation has recognized that hard drive failures may begin to increase an average of four to five years into the life of most computers used in industrial applications. Therefore, it is our recommendation as a preventive maintenance measure that all hard drives used in these types of applications be replaced before the four to five year time period to avoid any down time related to hard drive failure.

The purpose of this message is to merely bring this to our customer's attention, to offer alternative solutions, and to provide all of our customers with the excellent service they deserve.

Any questions regarding this issue may be directed to our support center at support@xycom.com.

Please note: Xycom recommends frequent backups of your hard drive, especially before beginning preventive maintenance procedures.

Product Repair Program / Returning a Unit to Xycom Automation

Xycom Automation's Product Repair & Customization Department (PR&C) restores equipment to normal operating condition and implements engineering changes that enhance operating specifications. Xycom Automation tests products returned to Xycom with the standard Xycom test diagnostics.

Note

Before sending the unit in for repair, back up the hard drive in case Xycom needs to restore the hard drive to the factory default O/S load.

Follow the steps below to prepare the unit for shipment:

1. Obtain a Return Merchandise Authorization (RMA) number for your unit by calling your nearest Xycom Automation Repair Department or Xycom Automation, Inc. at 734-429-4971.
2. Please have the following information:
 - Company name, shipping and billing address
 - Type of service desired: product repair or product exchange
 - Product model number, part number, quantity, serial number(s), and warranty status
 - Failure mode and failure systems
 - Purchase order number or repair order number
3. Make sure the front panel assembly is properly attached to the unit.
4. Attach failure information to the unit to speed processing.
5. Place the unit securely in its original packaging or an equivalent heavy-duty box.
6. Mark the RMA number on your purchase order and on the outside of the box.
7. Send the unit to the address given when you receive your RMA number.

Chapter 5 – Troubleshooting

Diagnostic Testing

If you suspect that you are having hardware problems with your 4115T, you can use the Xycom diagnostic utility to check out the PC's various ports and subsystems. The diagnostic utility is on the Documentation and Support Library CD that was included with the your unit.

The first step is to create a diagnostic diskette. The following steps can be done on any computer with a CD-ROM drive:

1. Create a DOS-bootable diskette
2. Create a temporary folder on the computer hard drive
3. There is a self-extracting zip file on the Documentation and Support Library CD located in:

DRIVERS\utility\xydiag

Run that program and extract the files to the temporary folder you just created.

4. Copy the extracted files onto the DOS-bootable diskette.

When you have created the diskette, insert it into the 4115T unit's floppy drive and re-boot the unit. The menu in Figure 5–2, *Main Menu*, will appear following boot-up. Additional information on the tests is included in the .txt files on the diskette.

Perform the following steps **before** starting the system tests:

1. Place the CPU board jumpers and switches to the factory set positions.
2. Plug the female end of the AC power cable into the side of the unit and the male end into a properly grounded outlet.
3. Connect the serial loopback connector(s) and the printer cable to the appropriate connectors, and connect a PC/AT or PS/2 keyboard. Figure 5–1, *Serial Loopback Connections*, illustrates the wiring necessary for the loopback connection.
4. Default the CMOS setup to the factory settings.

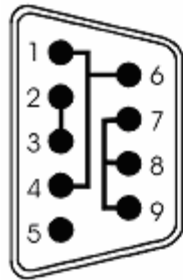

Com 1 RS-232
Serial Loopback
Connections

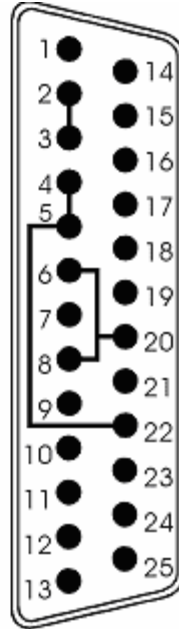

Com 2 RS-232
Serial Loopback
Connections

Figure 5-1. Serial Loopback Connections

Running the Tests

To run the test, insert the diagnostics disk into drive A. Turn on the computer (the diagnostics program will boot-up). Figure 5–2 shows the Main Menu.

```

          Copyright 2002, Xycom, Inc. All rights reserved.
          Diagnostic Tests Sequence/Selection Menu (Rel. xx)
1. WILL pause on error           5. Auto-select tests
2. SINGLE PASS test mode        6. Deselect all tests
3. Save setup to file           7. Quit and exit to DOS
4. Extract setup from a file     8. Return to previous screen

A) RAM Test                      K) Video Interface Test
B) Video RAM Test                L) Speaker Port Test
C) Extended RAM Test             M) LPT1: Printer Port Test
D) Real Time Clock Test          N) LPT2: Printer Port Test
E) COM1 Serial Port Test         O) C: Hard Drive Interface Test
F) COM2 Serial Port Test         P) D: Hard Drive Interface Test
G) COM3 Serial Port Test         Q) A: Floppy Drive Interface Test
H) COM4 Serial Port Test         R) B: Floppy Drive Interface Test
I) Math Coprocessor Test         S) Keyboard, Keypad Tests
J) Video Adjustments Test        = = Test Selected

          [ENTER]=START TESTING

Use the letters to move the cursor and select/deselect, or use the arrow
keys to move, then use the [SPACE] key to select/deselect a test or
function.

```

Figure 5-2. Main Menu

Note

Please read the DIAG.TXT file on the diagnostics disk for detailed information about the tests.

Note

Avoid repeated running of any hard disk diagnostic utility if you use the Solid State (Flash) drive option. The Flash drive has a limited number of writes to each logical sector. Repeated writes from a diagnostic utility will prematurely shorten the life of the drive.

Reinstalling Operating Systems

The 4115T CPU ships with Windows 2000 or Windows XP Professional operating systems installed. If you want to install a different operating system, refer to that operating system's manual for directions.

Note

If you need to reinstall the Windows 98, Windows 2000, Windows NT, or Windows XP Professional operating system, you must have an internal CD-ROM drive or an external parallel port CD-ROM drive. Windows NT and Windows XP ship only on CD-ROM.

Windows® 2000 Reinstallation

If you need to reinstall the Windows 2000 operating system, refer to the *Xycom Recovery for Xycom Automation Windows 2000 Workstation* (shipped with systems preinstalled with Windows 2000). This document is devoted to the reinstallation of your Windows 2000 operating system and drivers utilizing the Recovery Media provided with your Xycom Automation industrial computer.

Note

This procedure assumes that the computer hard disk drive has been completely corrupted or replaced.

Warning

This procedure will destroy data that may exist on the hard disk drive.

Windows XP® Reinstallation

If you need to reinstall the Windows XP Professional operating system, refer to the *Windows XP Professional* CD-ROM (shipped with systems preinstalled with Windows XP Professional).

Note

This procedure assumes that the computer hard disk drive has been completely corrupted or replaced.

Warning

This procedure will destroy data that may exist on the hard disk drive.

If you want to install a new operating system or reinstall a current operating system, refer to the operating system's manual for directions.

Installing Drivers

This section describes how to install the drivers associated with the system.

Note

For further assistance, call Xycom Automation technical support at 734-944-0482.

Video Drivers

Video drivers and the expansion utilities are on the Documentation and Support Library CD included with the documentation kit.

Choose the video driver for your operating system from the following directory on the Documentation and Support Library CD:

`\\DRIVERS\\4115R1_VIDEO.EXE`

Touch Screen Drivers

If you have a touch screen driver that has been factory installed, you will also receive, pre-loaded and at no extra charge: Windows 2000, and Windows XP Professional touch screen drivers.

Note

If you ordered a system pre-loaded with an operating system, the touch screen driver was pre-installed.

You must install the corresponding touch screen driver software if you change the operating system. The touch screen drivers are located on the Document and Support Library CD under:

`\\DRIVERS\4115TR1\TOUCHKIT_W2K_XP.EXE`

Miscellaneous Drivers

Refer to your operating system and peripheral manuals for information on installing drivers related to these items.

Note

If you ordered a system with Windows pre-loaded, you may have to purchase and install an external parallel port CD-ROM drive, or order your system with a CD-ROM drive pre-installed, to be able to install Windows drivers. The Windows operating system ships only on CD-ROM.

Appendix A Technical Specifications

This section contains the hardware and environmental specifications for the 4115T.

Hardware Specifications

The following table lists the hardware specifications for the 4115T.

Table A - 1. Hardware Specifications

Characteristic	Specification
Mechanical	
Height	12.16" (309 mm)
Width	16.14" (410 mm)
Depth	4.25" (108 mm) overall 3.94" (100 mm) behind front panel 0.315" (8 mm) front panel protrusion
Weight	21.3 lbs (9.66 kg)
Electrical	
AC	100-240 VAC 50\60 Hz 0.8A 125W *Nominal
Power Supply	200 watts
Mounting	Panel mount or 19" rack mount
Flat Panel	15" TFT active color display
Agency Approvals	UL 508 (Listed), E107636 cUL CSA C22.2, No. 142 (Listed), E107636
Regulatory Compliance	FCC 47 CFR, Part 15, Class A CE EMI EN55022, Class A IMMUNITY EN61000-6-2 SAFETY IEC60950-1 HARMONICS EN61000-3-2, Class A FLICKER EN61000-3-3

* Nominal Power is measured for a base configuration only. Any additional expansion and/or devices will increase the input power required.

Environmental Specifications

Table 1-4 lists the environmental and compliance specifications for the 4115T.

Table 1–4. Environmental and Compliance Specifications

Temperature	Operating	0°C to 50°C (32°F to 122°F)
	Non-operating	-20°C to 60°C (-4°F to 140°F)
Humidity	Operating	20% to 80% RH, non-condensing
	Non-operating	5% to 95% RH, non-condensing
Shock ¹	Operating	15g peak acceleration, 11 msec duration
	Non-operating	30g peak acceleration, 11 msec duration
Vibration (5-2000 Hz) ¹	Operating	0.006" peak to peak displacement 1.0g maximum acceleration
	Non-operating	0.015" peak to peak displacement 2.5g maximum acceleration
Altitude ²	Operating	Sea level to 10,000 ft. (3,000 m)
	Non-operating	Sea level to 40,000 ft. (12,000 m)

¹ These values are with solid state hard drives and not rotating media drives.

² Consistent with internal component specifications.

Appendix B – Watchdog Timer

The Watchdog Timer is a device to ensure that standalone systems can always recover from abnormal conditions that cause the system to crash. These conditions may result from an external EMI or a software bug. When the system stops working, hardware on the board will perform hardware reset (cold boot) to bring the system back to a known state.

A BIOS function call (INT 15H) is used to control the Watchdog Timer:

INT 15H:

AH – 6FH
<u>Sub-function:</u> AL-2: Set the Watchdog Timer's period BL: Time-out value (Its unit--second or minute, is dependent on the item "Watchdog Timer unit select" in CMOS setup).

You have to call sub-function 2 to set the time-out period of Watchdog Timer first. If the time-out value is not zero, the Watchdog Timer will start counting down. While the timer value reaches zero, the system will reset. To ensure that this reset condition does not occur, Watchdog Timer must be periodically refreshed by calling sub-function 2. However, Watchdog timer will be disabled if you set the time-out value to be zero.

A tolerance of at least 10% must be maintained to avoid unknown routines within the operating system (DOS), such as disk I/O that can be very time-consuming.

Note

When exiting a program it is necessary to disable Watchdog Timer, otherwise the system will reset.

Example assembly program:

```
; INITIAL TIMER PERIOD COUNTER
;
W_LOOP:

    MOV    AX, 6F02H                ;setting the time-out value
    MOV    BL, 30                    ;time-out value is 48 seconds
    INT    15H                       ;15H
;
; ADD YOUR APPLICATION PROGRAM HERE
;
    CMP    EXIT_AP, 1                ;is your application over?
    JNE    W_LOOP                    ;No, restart your application

    MOV    AX, 6F02H                ;disable Watchdog Timer
    MOV    BL, 0                      ;
    INT    15H

;
; EXIT
;
```

Appendix C – Power-On Self-Test Messages

POST Messages

During the Power-On Self-Test (POST) if the BIOS detects an error, it will either sound a beep code or display a message.

If a message is displayed, it will be accompanied by:

PRESS F1 TO CONTINUE, CTRL-ALT-ESC OR DEL TO ENTER SETUP

POST Beep

There are two kinds of beep codes in BIOS:

Single long beep followed by three short beeps—This code indicates that a video error has occurred and the BIOS cannot initialize the video screen to display any additional information.

Repeating long beep—This code indicates that a DRAM error has occurred.

Error Messages

One or more of the following messages may be displayed if the BIOS detects an error during the POST. This list includes messages for both the ISA and the EISA BIOS.

Table B-1. Error Messages

Error Messages	Cause/Solution
CMOS BATTERY HAS FAILED	CMOS battery is no longer functional. It should be replaced.
CMOS CHECKSUM ERROR	Checksum of CMOS is incorrect. A weak battery may have caused this error; replace if necessary. It may also indicate that CMOS has become corrupt.
DISK BOOT FAILURE, INSERT SYSTEM DISK AND PRESS ENTER	No boot device was found. This could mean that either a boot drive was not detected or the drive does not contain proper system boot files. Insert a system disk (formatted as a boot device) into Drive A: and press Enter. If you assumed the system would boot from the hard drive, make sure the controller is inserted correctly and all cables are properly attached, then reboot the system.
DISKETTE DRIVES OR TYPES MISMATCH ERROR - RUN SETUP	Type of diskette drive installed in the system is different from the CMOS definition. Run Setup to reconfigure the drive type correctly.
DISPLAY SWITCH IS SET INCORRECTLY	The display switch on the motherboard is set to a different setting than indicated in Setup. Determine which setting is correct and then either turn off the system and change the jumper, or enter Setup and change the VIDEO selection.

Error Messages	Cause/Solution
DISPLAY TYPE HAS CHANGED SINCE LAST BOOT	Since the last powering off the system, the display adapter has been changed. You must configure the system for the new display type.
EISA CONFIGURATION CHECKSUM ERROR PLEASE RUN EISA CONFIGURATION UTILITY	The EISA non-volatile RAM checksum is incorrect or cannot correctly read the EISA slot. This can indicate either the EISA non-volatile memory has become corrupt or the slot has been configured incorrectly. Verify the card is installed firmly in the slot. When this error appears, the system will boot in ISA mode allowing you to run the EISA Configuration Utility.
EISA CONFIGURATION IS NOT COMPLETE PLEASE RUN EISA CONFIGURATION UTILITY	The slot configuration information stored in the EISA non-volatile memory is incomplete. When this error appears, the system will boot in ISA mode allowing you to run the EISA Configuration Utility.
ERROR ENCOUNTERED INITIALIZING HARD DRIVE	Check that the adapter is installed correctly and all cables are firmly attached. Verify that the correct hard drive type is selected in Setup.
ERROR INITIALIZING HARD DISK CONTROLLER	See the cord is correctly and firmly installed in the bus. Verify the correct hard drive type is selected in Setup. Check jumper settings on the hard drive.
FLOPPY DISK CNTRLR ERROR OR NO CNTRLR PRESENT	Make sure the controller is installed correctly and firmly. If there are no floppy drives installed, be sure the Diskette Drive selection in Setup is set to NONE.
INVALID EISA CONFIGURATION PLEASE RUN EISA CONFIGURATION UTILITY	The non-volatile memory containing EISA configuration information was programmed incorrectly or has become corrupt. The system will boot in ISA mode allowing you to run the EISA Configuration Utility and correctly program the memory.
KEYBOARD ERROR OR NO KEYBOARD PRESENT	Make sure the keyboard is attached correctly and no keys are being pressed during the boot. If you are purposely configuring the system without a keyboard, set the error halt condition in Setup to HALT ON ALL, BUT KEYBOARD. This will cause the BIOS to ignore the missing keyboard and continue the boot.
KEYBOARD IS LOCKED OUT - UNLOCK THE KEY	BIOS detected the keyboard is locked. P17 of keyboard controller is pulled low.
MEMORY ADDRESS ERROR AT ...	Indicates a memory address error at a specific location. You can use this location along with the memory map for your system to find and replace the bad memory chips.
MEMORY PARITY ERROR AT ...	Indicates a memory parity error at a specific location. You can use this location along with the memory map for your system to find and replace the bad memory chips.
MEMORY SIZE HAS CHANGED SINCE LAST BOOT	Memory has been added or removed since the last boot. In EISA mode use Configuration Utility to reconfigure the memory configuration. In ISA mode enter Setup and enter the new memory size in the memory fields.
MEMORY VERIFY ERROR AT ...	Indicates an error verifying a value already written to memory. Use the location along with your system's memory map to locate the bad chip.
OFFENDING ADDRESS NOT FOUND	This message is used in conjunction with the I/O CHANNEL CHECK and RAM PARITY ERROR messages when the segment that has caused the problem cannot be isolated.
OFFENDING SEGMENT	This message is used in conjunction with the I/O CHANNEL CHECK and RAM PARITY ERROR messages when the segment that has caused the problem has been isolated.
PRESS A KEY TO REBOOT	This will be displayed at the bottom screen when an error occurs that requires you to reboot. Press any key to reboot.
PRESS F1 TO DISABLE NMI, F2 TO REBOOT	When BIOS detects a Non-maskable Interrupt condition during boot, this will allow you to disable the NMI and continue to boot, or you can reboot the system with the NMI enabled.
RAM PARITY ERROR - CHECKING FOR SEGMENT	Indicates a parity error in Random Access Memory.
SHOULD BE EMPTY BUT EISA BOARD FOUND PLEASE RUN EISA CONFIGURATION UTILITY	A valid board ID was found in a slot that was configured as having no board ID. When this error appears, the system will boot in ISA mode allowing you to run the EISA Configuration Utility.
SHOULD HAVE EISA BOARD BUT NOT FOUND PLEASE RUN EISA CONFIGURATION UTILITY	The board installed is not responding to the ID request, or no board ID has been found in the indicated slot. When this error appears, the system will boot in ISA mode allowing you to run the EISA Configuration Utility.
SLOT NOT EMPTY	A slot designated as empty by the EISA Configuration Utility actually contains a board. When this error appears, the system will boot in ISA mode allowing you to run the EISA Configuration Utility.

Error Messages	Cause/Solution
SYSTEM HALTED, (CTRL-ALT-DEL) TO REBOOT ...	The present boot attempt has been aborted and the system must be rebooted. Press and hold down the CTRL and ALT keys and press DEL.
WRONG BOARD IN SLOT PLEASE RUN EISA CONFIGURATION UTILITY	The board ID does not match the ID stored in the EISA non-volatile memory. When this error appears, the system will boot in ISA mode, allowing you to run the EISA Configuration Utility.
FLOPPY DISK(S) FAIL (80)	Unable to reset floppy subsystem
FLOPPY DISK(S) FAIL (40)	Floppy type mismatch
HARD DISK(S) FAIL (80)	HDD reset failed
HARD DISK(S) FAIL (40)	HDD controller diagnostics failed
HARD DISK(S) FAIL (20)	HDD initialization error
HARD DISK(S) FAIL (10)	Unable to recalibrate fixed disk
HARD DISK(S) FAIL (08)	Sector Verify failed
MANUFACTURING POST LOOP.	System will repeat POST procedure infinitely while the P15 of keyboard controller is pulled low. This is also used for M/B burn in test.
BIOS ROM CHECKSUM ERROR - SYSTEM HALTED.	The checksum of ROM address F0000H-FFFFFFH is bad.
MEMORY TEST FAIL.	BIOS reports the memory test failed if the onboard memory is tested error.

Appendix D – DMA, IRQ and 1st MB Memory

DMA Channel Assignments

Table C-1. DMA Channel Assignments

Channel	Description
0	Available
1	Available
2	Floppy Disk (8-bit transfer)
3	Available
4	Cascade for DMA controller 1
5	Sound
6	Available
7	Available

IRQ Mapping Chart

Table C-2. IRQ Mapping

IRQ0	System Timer	IRQ8	RTC Clock
IRQ1	Keyboard	IRQ9	AC97 Audio
IRQ2	IRQ Controller	IRQ10	IRQ Holder for PCI steering
IRQ3	(COM2)	IRQ11	ICH4 USB2.0
IRQ4	(COM1)	IRQ12	PS/2 Mouse
IRQ5	Intel ICH4 LAN	IRQ13	FPU
IRQ6	FDC	IRQ14	Primary IDE
IRQ7	LPT1	IRQ15	Secondary IDE

Note

All IRQs have been assigned to the listed devices, so if you want to add any additional device interface, you must free the unused IRQ first. For example, if you don't use USB K/B or Mouse, then IRQ10 may be set free.

1st MB Memory Address Map

Table C–3. 1st MB Memory Address Map

Memory Address	Description
00000-9FFFF	System Memory
A0000-BFFFF	VGA Buffer
C0000-CFFFF	VGA BIOS
E0000-FFFFFF	System BIOS
100000	Extended Memory

I/O Addresses

Table C–4. I/O Addresses

I/O Address Range	Description
000-01F	DMA Controller #1
020-021	Interrupt Controller #1, Master
040-05F	System Timer
060-06F	Standard 101/102 keyboard controller
070-07F	Real Time Clock, NMI controller
080-09F	DMA Page Register
0A0-0BF	Interrupt Controller #2
0C0-0DF	DMA Controller #2
0F0-0F0	Clear Math Coprocessor Busy
0F1-0F1	Reset Math Coprocessor
0F8-0FF	Math Coprocessor
408-409	Digital Input/Output
170-1F7	Fixed Disk
278-27F	Parallel Printer Port (LPT2)
2E8-2EF	Serial Port 4 (COM4)
2F8-2FF	Serial Port 2 (COM2)
376-376	BUS Master PCI IDE Controller
378-37F	Parallel Printer Port 1
3A0-3AF	Bisynchronous 1
3B0-3DF	Intel 82845G/GL Graphic Controller
3F0-3F7	Floppy Disk Controller
3E8-3EF	Serial Port 3 (COM3)
3F0-3F7	Diskette Controller
3E8-3EF	Serial Port 3 (COM3)
3F8-3FF	Serial Port 1 (COM1)
480-48F	PCI BUS

Appendix E – How to Use the Wake-Up Function

POS-478E provides two kinds of Wake-Up functions: Modem Wake-up and LAN Wake-up. The Wake-Up function will be activated when ATX power supply is in use.

Wake-Up On Modem (Ring)

Wake-Up On Modem is set in CMOS SETUP. Activating this function allows the ATX power supply to be switched on when there is a ring signal detected on pin “RI” of the serial port.

Wake-Up On LAN

When your computer is in power-down status, the LAN Link/Active LED will flash, indicating that the LAN chip has entered standby mode. The LAN chip is waiting for a Wake-Up signal to become active. You can use other computers to wake up your computer by sending an ID to it. An ID is the address of your system LAN; every LAN chip has a factory-set ID. The LAN ID can be found in the network information section in Microsoft Windows. The ID format is xxxxxxxxxxxx. (Example ID: 009027388320)

Appendix F – How to Upgrade a New BIOS

Please contact the Xycom Automation Application Engineering Department at 734-944-0482 to obtain the latest BIOS.

BIOS Update Procedure

Notes

- A. This procedure will erase any prior data on that floppy, so please proceed accordingly.
- B. Typically four files will be transferred, only COMMAND.COM being visible when running a simple directory listing.
- C. Please leave the diskette un-write protected for the balance of this procedure.

1. Make a boot disk. Go to the DOS command prompt in MS-DOS or Windows 9x and, with an available floppy disk in "A", type "format A:/s" That will format the floppy and transfer the needed system files to it.
2. Download the BIOS upgrade file and awdfash.exe utility from an ICP web site to a temporary directory on your hard drive, or directly to the floppy formatted in step 1.
3. Copy (BIOS file and awdfash.exe) files to the boot floppy disk.
4. Reboot the system to the DOS command prompt using the boot disk made in the previous steps.
5. At the DOS command prompt, awdfash filename.xxx, (filename.xxx is the file name of the upgraded BIOS file), press Enter.
6. The first prompted option is to save the old BIOS. It is recommended that this option be selected in case it is later decided not to use the new version once it is installed. To save, enter Y. To not save, enter N.

Notes

- A. DO NOT save the old BIOS with the same file name as the new BIOS. If the same file name is used, the new BIOS will write over the old BIOS with no prompted warning.
- B. If the old BIOS is not saved write down the version number of the old BIOS and store it with your important computer documents. If not saving old BIOS, enter N (for "no") and skip to step 9.

7. Enter a NEW name for the old BIOS file, press Enter.
8. The second prompted option will be whether you want to flash your BIOS. Enter Y for yes, N for no.

Warning

Once the Enter key is pressed, DO NOT touch the keyboard, reset button, or power switch while flashing is in progress. A progress bar on the screen will show the progress of the flashing.

9. When the flashing process is complete, you will be asked to reset or power off the system. Remove the floppy disk from the drive and reset or power off the system.
10. Reboot the system and note that the BIOS version on the initial boot-up screen has changed to the new BIOS version. Your BIOS upgrade is now complete.

Recovering Your Old BIOS

1. Boot the system with the floppy disk that contains the new BIOS. If you do not have the floppy disk, repeat steps 1, 2, and 3 of the BIOS Upgrade Procedure above for the version of the BIOS recovering.
2. Complete steps 4 and 5 (filename.xxx is the name of the recovered BIOS file). Select N for no in step 6, and continue with steps 8, 9, and 10.

Install screen:

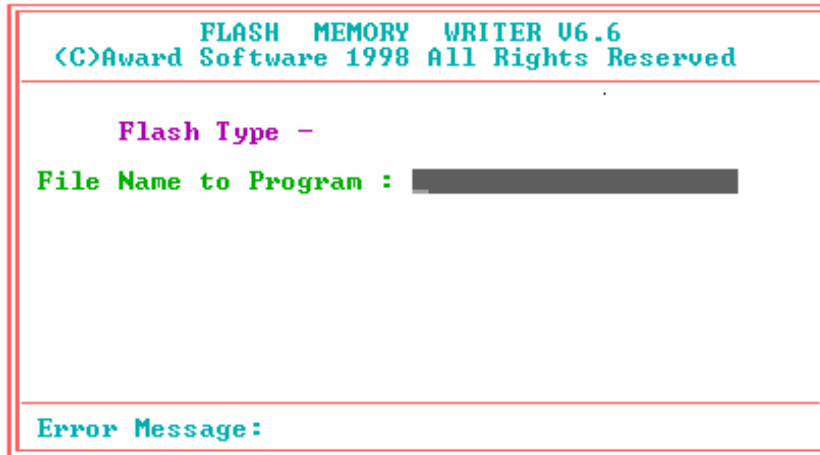

Figure D - 1. BIOS Upgrade Screen

Index

Arm mounting.....	13	specifications.....	1
Award BIOS setup.....	14	Maintenance.....	46
BIOS recovery.....	66	general.....	46
BIOS setup.....	14	hard drive.....	46
getting help.....	32	Mechanical diminsions.....	8
main menu.....	33	Memory address (1 st MB) map.....	63
overview.....	31	Memory map.....	62
standard CMOS features.....	34	Mounting	
starting.....	31	arm.....	13
using.....	32	panel.....	9
BIOS upgrades.....	65	wall.....	11
CPU board.....	14	Operating systems	
layout.....	15	installation.....	51
product overview.....	14	Panel mounting.....	9
specifications.....	14	POST messages.....	58
Dimensions		Power on self test.....	58
mechanical.....	8	error messages.....	58
DMA channel assignments.....	62	POST beep.....	58
DMA, IRQ and memory map.....	62	POST messages.....	58
Documentation kit.....	5	Preventive maintenance.....	46
Drivers		general.....	46
installing.....	52	hard drive.....	46
miscellaneous.....	53	Product information	
touch screen.....	52	CPU board.....	14
video.....	52	environmental specifications.....	55
Environmental specifications.....	55	general.....	1
Error messages (power on self test.....)	58	LCD display.....	1
Fuse		mechanical dimensions.....	8
replacement.....	46	touch screen.....	2
General information.....	1	Product specifications	
I/O address map.....	63	environmental.....	55
Input/output address map.....	63	LCD display.....	1
Installation		touch screen.....	2
driver.....	52	Recovering the old BIOS.....	66
operating systems.....	51	Repairs and service.....	47
IRQ map.....	62	Reverse side of unit	
LCD display		system setup.....	2, 3

Service and repairs	47	side view of unit.....	4
Side view of unit		wall mounting	11
system setup	4	Touch screen	
Specifications		specifications.....	2
CPU board	14	Touch screen drivers.....	52
environmental.....	55	Unit reverse side	2, 3
LCD display	1	Unit side view	4
touch screen.....	2	Upgrading the BIOS	65
System setup		Video drivers	52
arm mounting	13	Wall mounting	11
panel mounting.....	9	Watchdog timer	56
reverse side of unit.....	2, 3		

143926(A)

Xycom Automation, Inc.
734-429-4971
Fax: 734-429-1010
<http://www.xycom.com>

Canada Sales: 905-607-3400
Northern Europe Sales: +44-1604-790-767
Southern Europe Sales: +39-011-770-53-11

